

# HELIOS ROTARY HOE

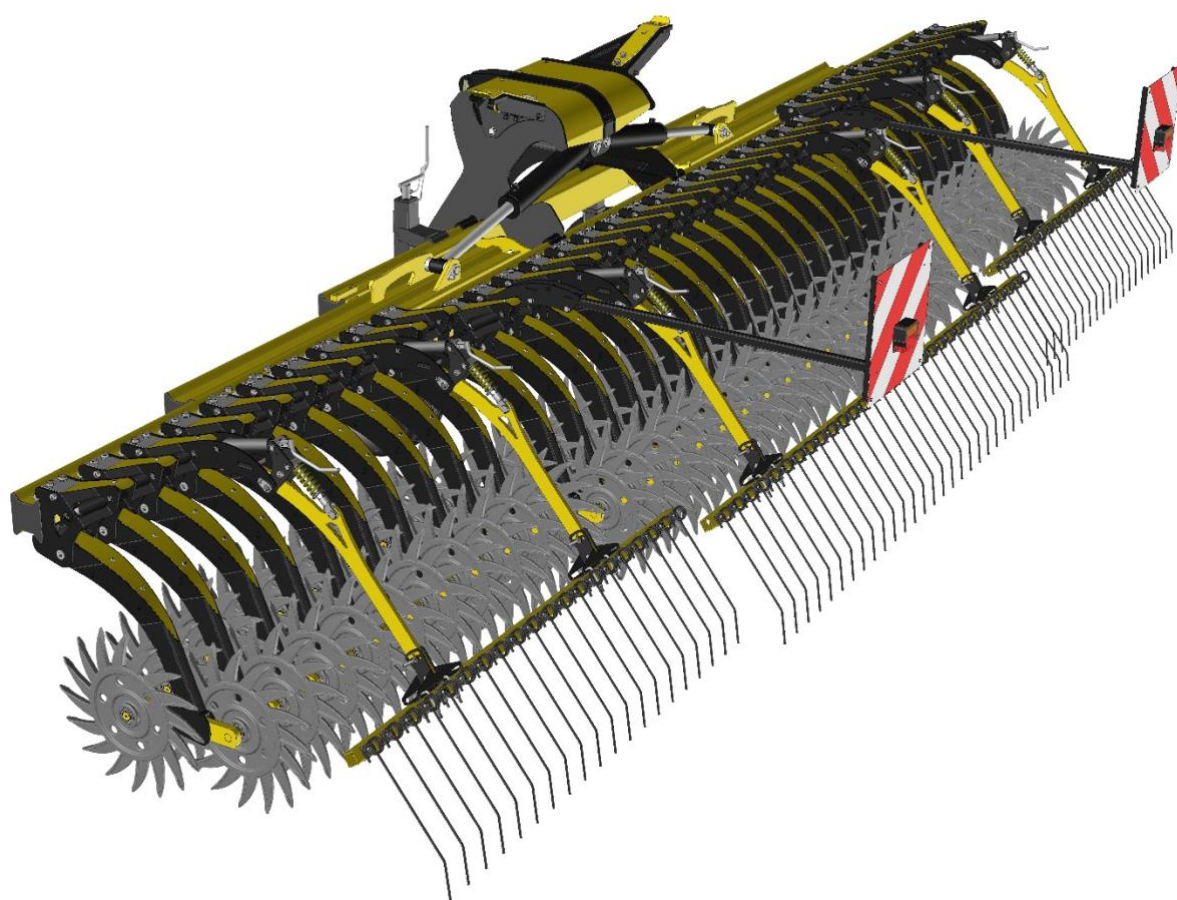

## **B.C. TECHNIQUE AGRO-ORGANIQUE S.A.S.**

Contents:

1. Conformity statement and device identification.....	5
--	---

1.1.	Conformity statement.....	5
1.2.	Data plate .....	6
<b>2.</b>	<b>General safety rules .....</b>	<b>7</b>
2.1.	Obligations and responsibilities .....	7
2.2.	To do before use .....	7
2.3.	Description of safety symbols .....	7
2.4.	Warning signs .....	8
2.5.	Safety instructions.....	10
2.5.1	Safety instructions relevant to the machine's setup and maintenance.....	10
2.5.2	Safety instructions for road transport .....	10
2.5.3	Safety instructions during the machine's operation .....	11
<b>3.</b>	<b>Introduction to the machine.....</b>	<b>12</b>
3.1.	General information.....	12
3.2.	Coupling of the rotary hoe .....	12
3.3.	Gauge wheels.....	12
3.4.	Uncoupling stands.....	13
3.5.	Rotary hoe elements.....	13
<b>4.</b>	<b>Set-up.....</b>	<b>14</b>
4.1.	Tractor requirements .....	14
4.2.	Coupling.....	14
4.3.	Hydraulic connection .....	15
<b>5.</b>	<b>General settings .....</b>	<b>16</b>
5.1.	Foreword .....	16
5.2.	Chassis adjustment.....	17
5.3.	Hoeing elements adjustment.....	18
5.3.1.	Spacing .....	18
5.3.2.	Ground pressure adjustment .....	18
5.4.	Rear comb setting .....	19
5.4.1.	Ground pressure adjustment .....	19
5.4.2.	Setting the teeth's aggressiveness.....	20
<b>6.</b>	<b>Maintenance and servicing.....</b>	<b>21</b>
6.1.	Maintenance and servicing .....	21
6.2.	Cleaning.....	21
6.3.	Instructions for storage .....	21

---

<b>7. Hydraulic circuit</b> .....	22
7.1. Folding with mechanical lock .....	22
7.2. Hydraulic depth setting (SoftControl option) .....	23
<b>8. Nomenclature</b> .....	24
8.1. Coupling .....	24
8.2. Châssis .....	26
8.3. Gauge wheels .....	28
8.4. Hoeing elements .....	30
8.4.1. Hoe's arm .....	30
8.4.2. Comb support .....	32
8.5. Road lighting equipment .....	34
<b>9. Notes</b> .....	36

Dear user,

First we would like to thank you for your confidence and hope that your HELIOS rotary hoe will give you full satisfaction.

The few minutes you will spend reading this leaflet will allow you to use the full performances of your HELIOS Row hoe, to save its service life and work in full safety conditions.

This user guide is an important document, keep it safe and refer to it if needed. Provide it to any other user and to the new owner, should you resell it.

Should any picture or technical data included in this document not be precisely matching your HELIOS Row hoe, operating conditions would however remain unchanged.



---

# 1. Conformity statement and device identification

## 1.1. Conformity statement



The manufacturer:

**BC TECHNIQUE AGRO-ORGANIQUE**  
**Bois Choppard**  
**F-89270 VERMENTON**

Declares the the devices:

**HELIOS Rotary hoe**

Serial nr:

Fulfil the statements of directive 2006/42/CE of European parliament  
and council dated May 17th, 2006 suitable to machines.

Vermenton, on :    /    /    .

**Mathias BOUNON**  
Chairman  
B.C. TECHNIQUE AGRO-ORGANIQUE S.A.S

1.2. Data plate

**PHENIX**  
AGROSYSTEM

Désignation /  
Type :

N° de série /  
Serial number :

Poids / Weight :

Année / Year :

Bois Choppard F-89270 VERMENTON

CE

Appear on this plate designation and serial number both required for any request of information, spare parts or technical support.

## 2. General safety rules

### 2.1. Obligations and responsibilities

These instructions should be considered only as guidelines, and non-binding, in any case for neither BC TECHNIQUE's nor its representative's responsibility. The entire responsibilities of operation, road transportation, maintenance and servicing lies with owners and operators.

The owner and operator are entirely liable for the correct operation of the device in every respect. The owner is also responsible of ascertaining the staff operating the device read and understood these instructions and works in accordance with regulations and provisions in force.

Should one of the device's operators find out a breach of security rules, this must be addressed immediately.

Prior to delivery, every machine is submitted to quality inspection and tries in operation. However, the operator/owner remains fully liable of of the device's proper operation in the field.

Modifications applied to the machine's design are part of our continuous improvement process. The machine's description apply to its configuration at the time of this leaflet's writing. The user guide may include pictures showing a machine that does not match exactly yours, depending on model, options or performed upgrades.

### 2.2. To do before use

-Carefully read these instructions and make sure their content being understood.

-Learn to operate properly the machine, keeping prudent.

If operated by an untrained operator, or neglectfully used, the machine may turn out to be hazardous.

The machine will be part of the user and colleague's workplace. Therefore, care has to be

taken of everyone's safety and of proper use of individual protection equipment.

### 2.3. Description of safety symbols



Always pay particular attention to instructions or diagrams highlighted by this symbol. This symbol warns against a deadly hazard, serious physical injuries or important material damage should no action being taken to avoid it.



This symbol calls to a particular situation or required action to ensure proper use of the machine. Breaching these instructions may result in issues affecting either the machine or its surroundings.







Information involved in this symbol are of interest, because they offer advice or particularly useful information about the proper operation of the machine.

## 2.4. Warning signs







	<p><b>Prior to putting the machine into use, please read the user guide and fulfil the safety instructions its states.</b></p>
	<p><b>Be regularly checking the working parts tightening.</b> Fulfilling this instruction will held you avoiding:</p> <ul style="list-style-type: none"> <li>• The falling of elements able to harm your safety.</li> <li>• The loss of parts (out of warranty)</li> <li>• The deterioration of your machine</li> </ul>



	<p><b>Risk of crushing due to machine's parts in action !</b>          This may cause extremely serious injuries.          Stay away from equipment tilting.          Avoid anyone remaining in this dangerous zone as long as the tractor's engine is running and hydraulic and electronic systems are into action.</p>
	<p><b>Risk of injury by contact with high pressure hydraulic fluid leaking, due to hydraulic hose's sealing defect.</b>          High pressure hydraulic fluid jet leaking may penetrate the skin and result in extremely serious or lethal injuries.</p> <ul style="list-style-type: none"> <li>• Never be trying under any circumstance to plug a hydraulic hose leak with fingers or hands.</li> <li>• Please read and fulfil safety instructions from the user guide leaflet prior to proceeding in any servicing or repairing hydraulic hoses.</li> <li>• Should such injury happen, immediately consult a doctor.</li> </ul>
	<p><b>Risks of crushing between the tractor's back and the machine when coupling or uncoupling it.</b>          This may cause extremely serious injuries or death.</p> <ul style="list-style-type: none"> <li>• It is forbidden to activate the tractor's 3-points hitch hydraulic circuit as long as people stand between the tractor's back and the machine.</li> <li>• Action levers of the 3-points hitch should be actioned             <ul style="list-style-type: none"> <li>- only from the working zone dedicated to that purpose</li> <li>- never, under any circumstance, when you are standing in the hazard zone between the tractor and the machine.</li> </ul> </li> </ul>
	<p><b>Hazardous situations for the operator when taking action to the machine, for example when mounting, setting up, troubleshooting, cleaning, servicing or repairing, due to the machine's inadvertent start or move!</b>          Possible risk may result in severe body injuries and death.</p> <ul style="list-style-type: none"> <li>• Prior to any action on the machine, have every measures taken to prevent inadvertent start or move.</li> <li>• Regarding the type of action to be taken, read and fulfil the instruction of the relevant chapter of this user guide leaflet.</li> </ul>

## 2.5. Safety instructions



### 2.5.1 Safety instructions relevant to the machine's setup and maintenance

	Always park the device on a plain and steady ground.
	The machine is featured with a hydraulic circuit, under pressure when the rotary hoe is coupled to a tractor. Always stop the tractor (and disconnect power source depending on option) during every repair or maintenance action taken to the rotary hoe.
	Regularly check 3-points hitch's balls and pins for wear.
	Prior to connecting the hydraulic hoses, always make sure the male connectors of the rotary hoe and the female connectors of the tractor are clean and free from dust.
	In order to safeguard the quality and safety of the equipment, only original BC TECHNIQUE spare parts are to be used. Terms of warranty as well as any claim referring it will be void, should non-original spare parts having been used.

### 2.5.2 Safety instructions for road transport

	The entire responsibility of transport on public roads lies on the owner and driver.
	Having first coupled the carriage, make sure that at least 20% of the tractor's weight bears upon the front wheels. This will preserve the carriage's manoeuvrability during the drive.
	To avoid any hazard resulting from errors during the drive on roads, the whole electronic control equipment, either outside or inside the cabin, must be shut off before beginning to drive.

**2.5.3 Safety instructions during the machine's operation**

	<p>When the tractor's engine is running, make sure that surrounding people stand at a sufficient safe distance from any suspended load, and from any lifted or mobile machine member.</p>
	<p>Every time there is work being done beneath the machine, or every time there is a risk of injury by crushing, the machine has to be fully and properly lifted and supported. Use some stands.</p>

## 3. Introduction to the machine

### 3.1. General information

All optional features can be subsequently mounted to the basic machine.



Post-delivery assembly should be performed only by required technical-skilled staff.

### 3.2. Linkage of the rotary hoe

The HELIOS rotary hoe is originally featured with standard linkage cat.II.

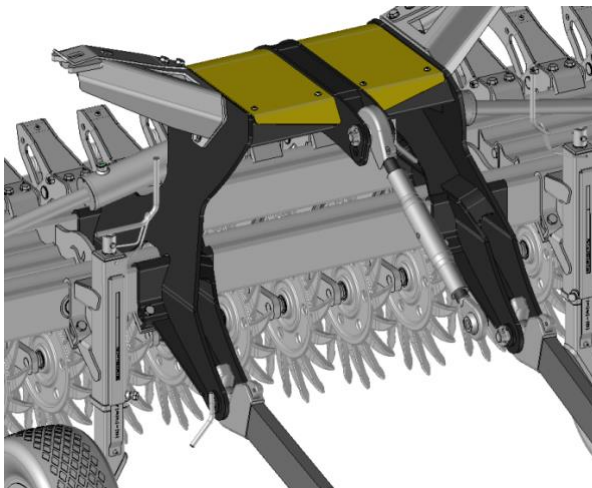

To provide more safety during road drive, it is also featured with a mechanical locking system in folded position.

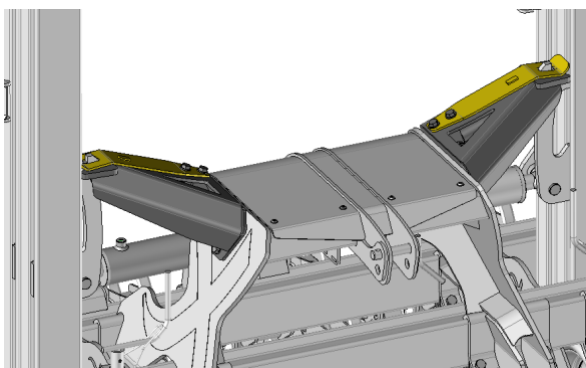

### 3.3. Gauge wheels

The gauge wheels are fitted with spring-lockable handles ① and graduations. A tightening screw ② allows to definitely secure the final adjustment (voir §5.2).

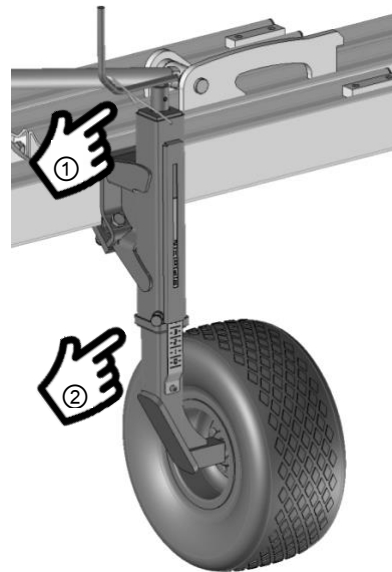

Tires pressure:

<i>Tire dimensions</i>	<b>18.5 x 8.50 - 8</b>
<i>Recommended pressure</i>	<b>5 bars / 73 Psi</b>
<i>Max. pressure</i>	<b>6.3 bars / 92 Psi</b>

### 3.4. Unfitting the stands

The 2 stands ensure the stability of your rotary hoe when uncoupled from your tractor.

Driving on road is allowed only when the stands are off.

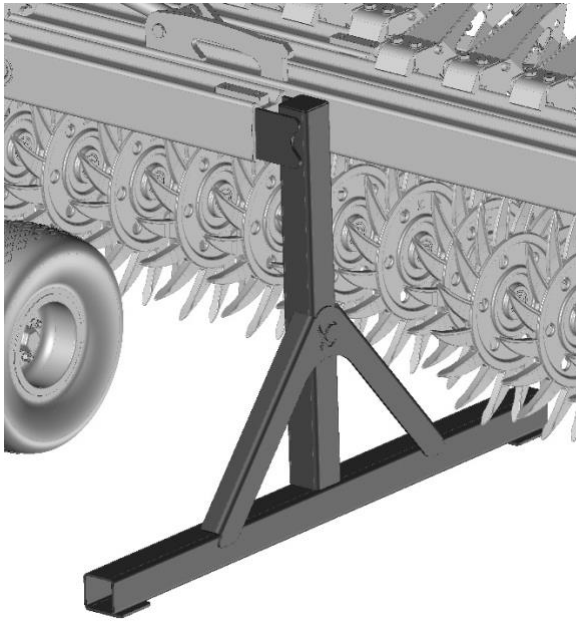

For better safety we recommend storing your rotary hoe unfolded on a plain and steady ground.

### 3.5. Rotary hoe elements

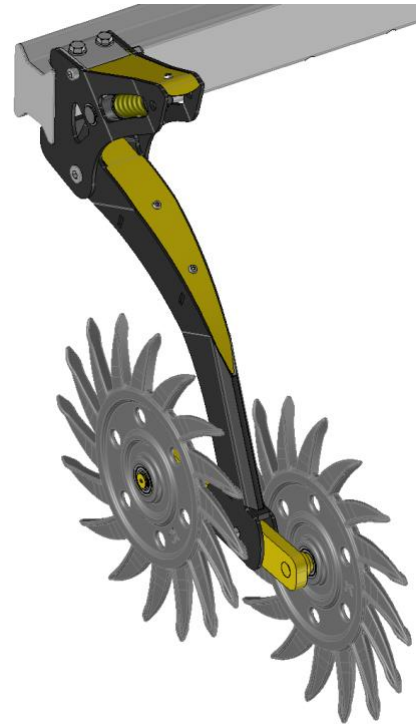

The main components of the tilling section are:

- Attachment with pressure adjustment
- Arms
- Boggies
- Ground-driven wheels
- Rear comb harrow

## 4. Set-up

### 4.1. Tractor requirements

The HELIOS rotary hoe is featured with standard linkage cat.2. Depending on the working width (from 4.8 m to 6.4 m), the selected tractor should feature at least a 90 HP power.

The tractor should not be coupled to the machine if either the maximum load per axle or its specific maximum total authorized weight is exceeded.

The tractor must feature:

- a 3-points hitch cat. 2 (ou 3)
- 1 or 2 double-action hydraulic valves, depending on the device's options.

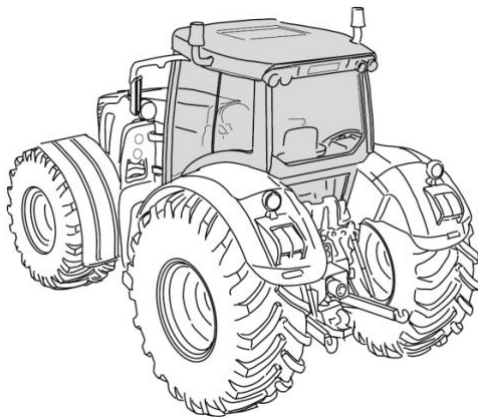

The tractor's cab should be designed to protect the operator from debris and dust which are dangerous for his health.

### 4.2. Hitching

1. Adjust both the tractor's hitch's arms so they stand the same height.
2. Should the tractor feature quick-hitching hooks (recommended) adjust the width between the hitch's arms so the optimal center distance of 875mm is fulfilled.

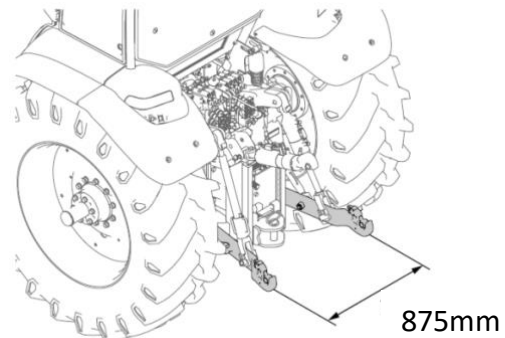

3. Drive in reverse gear till the tractor comes about one meter away in front of the hoe's linkage points. Engage the tractor's parking brake.
4. Connect the hydraulic hoses.
5. Drive one more meter backwards to the linkage points.



Nobody should be standing between the tractor and the rotary hoe during the tractor's reverse drive.

6. Couple the rotary hoe's three points to the tractor's.
7. Lift the machine
8. Have the stands off.

### 4.3. Hydraulic connection

Connect the hydraulic hoses to the tractor's hydraulic connectors. Carefully check that all hoses are properly connected to the relevant hydraulic connector.



Carefully clean connectors and adaptors. This will prevent a lot of issues, as well as early wear of the hydraulic circuit.

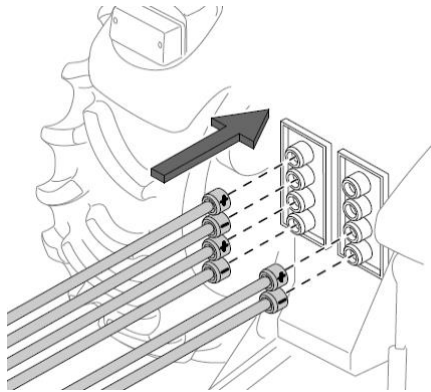

---

## 5. General settings

### 5.1. Foreword

Further that letting you take advantage of the quality of its equipment, B.C. Technique Agro-organique is able to provide you with advice for your agronomic operations.

The HELIOS rotary hoe mechanically destroys weeds and airs the soil to boost the growing crop.

Under any soil condition, even then most demanding ones (slaking crusty, clay, pebbly or residue-cluttered soils), the HELIOS rotary hoe fulfils its purpose with no default.

Working speed impacts the rotary hoe's aggressiveness. We recommend working at around 5 to 13 km/h.

Notice that working speed must be adjusted regarding the crop stage. The younger the crop, the slower the speed must be to avoid destroying plants.

Working depth also impacts the hoe's aggressiveness. It can be adjusted using the gauge wheels, and should never exceed 3 cm not to generate new weeds germinations.



#### ***We recommend:***

- . Operate on very young weeds (white-thread to 2-leaves stage) Early passes are possible, even before the cereal emerges, or from 3-leaves to early-tillering stage.
- . Have a proper soil tillage done. Seedbed must be tamped enough and levelled to control the working depth of the device.
- . Have a ground free from large debris or pebbles.

- . Check the hoe's level (adjustment of 3-points and lifting links)
- . Operate on a just-dried soil A too dry or too thick staking crust reduces the star-wheels soil penetration and the weeding effectiveness.
- . Operate at hottest times of the day (weeds more effectively drying)



#### ***We do not recommend:***

- . Weeding too deep This may result in generating new weeds germinations and weaken the growing crop.
- . Operate under too moist or too dry conditions

## 5.2. Chassis adjustment

- Having the machine unfolded and laying on a plain ground, adjust first the chassis level parallel to the ground using the tractor's top link's arm length.

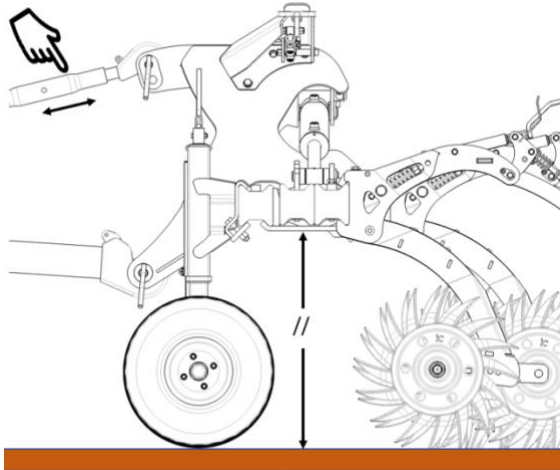

- Using the front gauge-wheels handles, adjust the chassis height which will set the working depth of the star-wheels. Graduations will allow a right similar setting of both gauge-wheels.

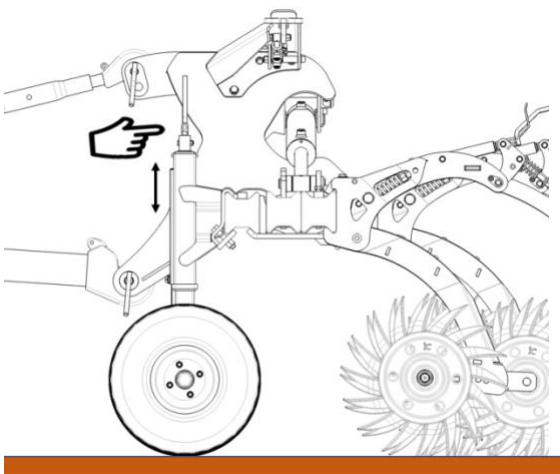

- The rotary hoe features two gauge-wheels as standard. Their track-width has to be adjusted to fit the tractor's track.

To make this setting:

- Unscrew the screws of each wheel-holder
- Slide the wheel-holder on the chassis tube profile and place it at the intended track's width.
- Tighten the wheel-holder's screws again

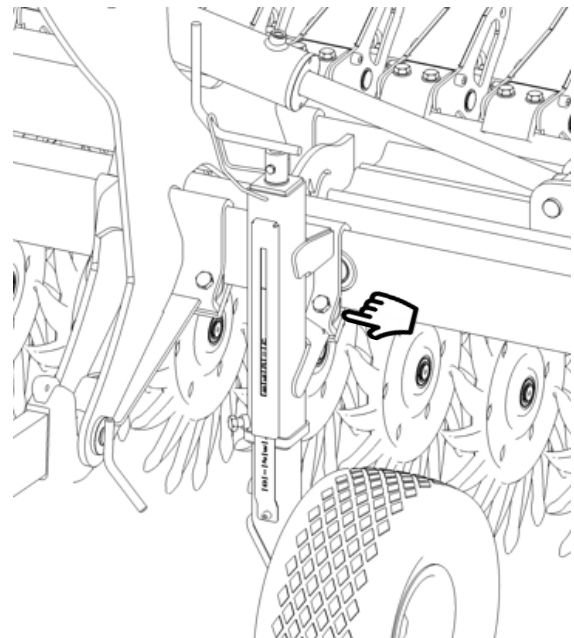

### 5.3. Hoeing elements adjustment

#### 5.3.1. Spacing

Hoeing elements are fitted to the chassis with clamp jaws. They are set in our works with a 18-cm spacing in order to get 9 cm between two star-wheels. Elements are independent. For specific crops, some may be unfitted, or the spacing between them may be modified. (mechanical version of the hoe only).

To make this setting:

- Unfasten the 2 screws that fit the jaws to the beam
- Slide the elements on the chassis tube profile and place them at the intended spacing.
- Fasten the 2 screws again.

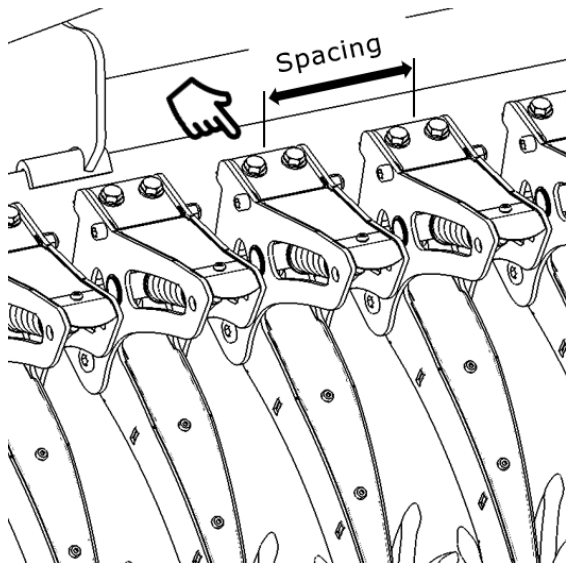

#### 5.3.2. Ground pressure adjustment

##### -Mechanical rotary hoe

Ground pressure (penetration force) is adjusted by tightening the nut depicted below. Make sure the very same setting applies to each and every element.

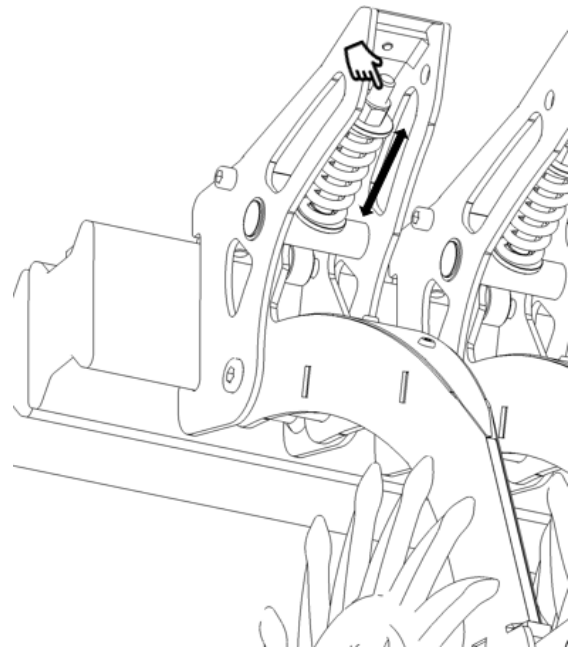

Tips and tricks: Slightly increase the pressure set to the elements located behind the tractor's wheels tracks. (Compacted areas)

**- Hydraulic rotary hoe**  
**(SOFT CONTROL as an option)**

Elements are controlled by a general hydraulic circuit that distributes the machines weight all over them. This system provides a perfect working depth for every element, whatever the ground's relief. All the elements keep the same equal ground pressure whatever their position.

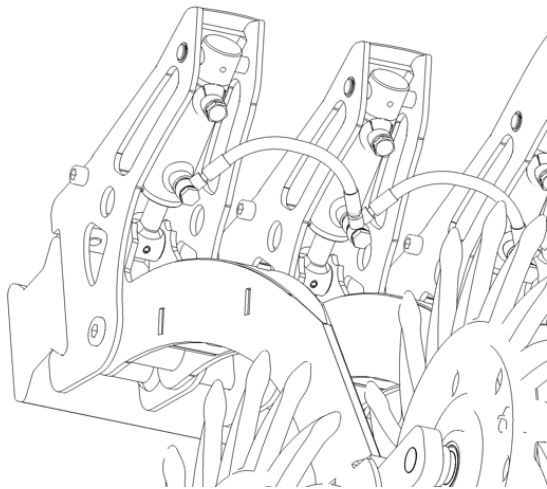

To make this setting:

- Have your hoe coupled to your tractor and the hydraulic circuit connected to one of your tractor's single action distributor.
- Have the hoe unfolded and landed on a plain ground.
- Adjust the gauge wheels height and the rear comb harrow (§ 5.4.1 )
- Add some volume of fluid in the hydraulic circuit with the tractor's distributor until the hoe's gauge wheels are slightly lifted off the ground.
- This setting will have to be completed on the field once viewed the working depth and operating conditions (soil type, moisture, crop...)
- Once this setting done, close the circuit's isolation valve.



Tips and tricks: Each element is fettet with a hydraulic ram. For a proper operation, we suggest adjusting the setting so the rams work half-extended.

**5.4. Rear comb setting**

Your HELIOS hoe is fitted as standard with a rear comb featuring various independent settings.

**5.4.1. Ground pressure adjustment**

Each support arm of the comb is fitted with a load spring setting system.

How To make this setting:

- Raise the lock ①
- Screw the handle ② to relax the load spring (smaller comb pressure on the ground)
- Unscrew the handle ② to compress the load spring (bigger comb pressure on the ground)
- Lower the lock ① when your setting is done.

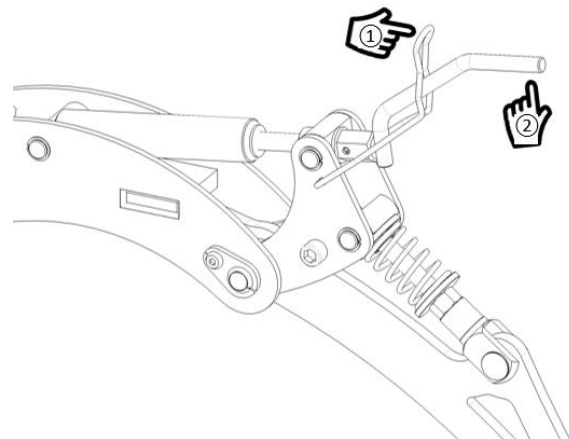

#### **5.4.2. Setting the teeth's aggressiveness**

Each support arm of the comb is fitted with a load spring setting multi-position system.

How To make this setting:

- Take off the spring pin
- Take off the pin
- Position the teeth-holder at the required angle (3 fixed positions + 1 floating )
- Insert the pin into the selected hole or cut-out, then put the spring pin on again.

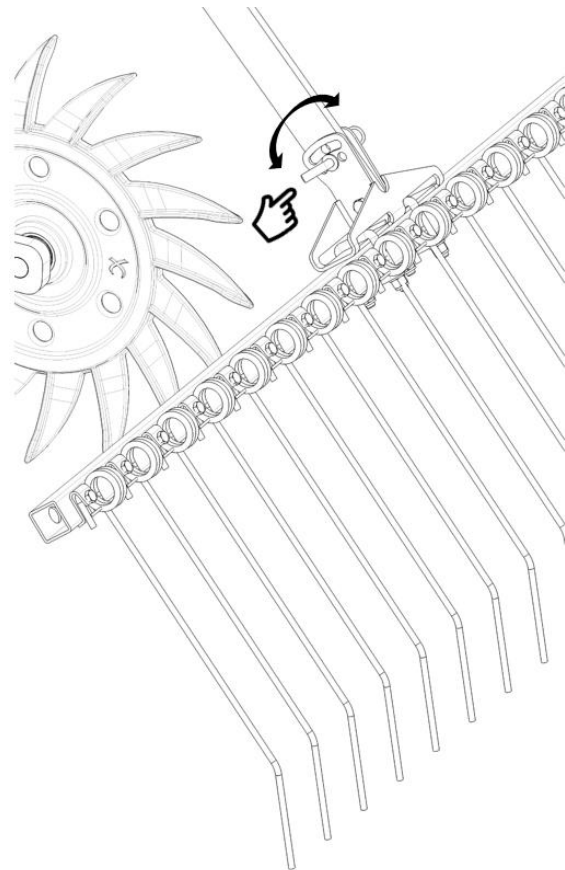

#### Tips and tricks:

The combs offset is adjustable. For the work's quality, we suggest positioning the teeth in such manner that they till the soil stripes between the star-wheels tracks.

## 6. Maintenance and servicing

Please fulfil the storage, maintenance and servicing instructions stated below so you make sure your devices remain in perfect operating condition.

### 6.1. Maintenance and servicing

Prior to using your hoe:

- Check that screws and nuts are properly tightened.
- Check that hydraulic hoses and connectors are not damaged.
- Check the tires pressure.
- Check that no accretion of pebble or earth impedes the device operation.



#### **Greasing the wheels hubs::**

Unfit the hubs taps and fill in grease.

Frequency: Once a year.

In order to guarantee the safety of your HELIOS rotary hoe's operation, as well as its service life, always use manufacturer's original spare parts. Fitting any other spare part the the manufacturer's will result in voiding the warranty.



---

Your machine holds the CE compliance mark. Use only new and original B.C. TECHNIQUE-approved spare parts.

---

### 6.2. Cleaning

When performing the clean-up with a HP cleaner, please spare the joints, rams, rollers, bearings.

For your own safety, wear individual protection equipment (gloves, glasses, ...)

### 6.3. Instructions for storage

Your HELIOS rotary hoe includes hydraulic systems, we suggest that it is to be stored in a covered dry place.

Prior to uncouple your machine, make sure the storing spot's ground is plain, clean and steady.

- Use the provided stands to stabilize the machine during and after uncoupling.
- Remove the pressure in the hydraulic circuits by using the tractor's controls (with engine stopped)



---

Never let children play on or around a farm machine.

---

## 7. Hydraulic circuit

### 7.1. Folding with mechanical lock

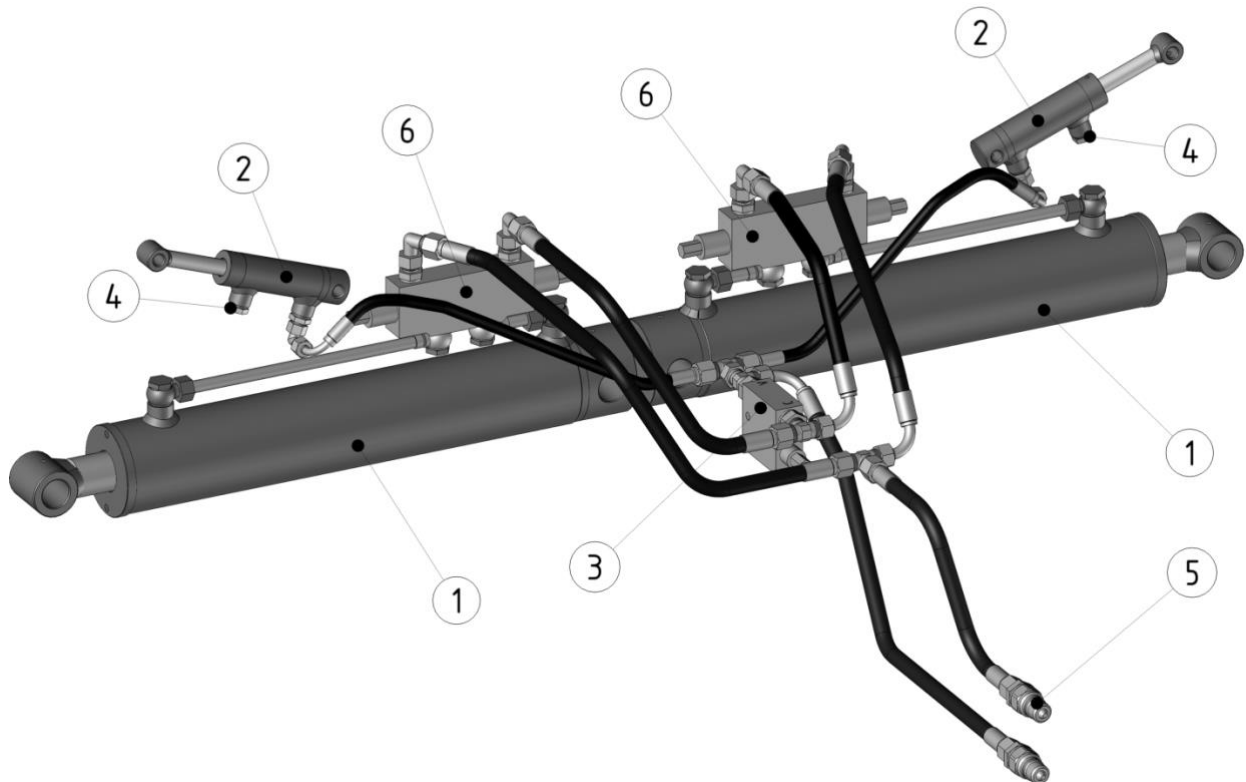

Mark	Reference	Designation
1	VH2P	Ram
2	VH1P	Ram
3	CHY17	Sequence valve
4	CHY18	Breather
5	CHY19	Male connector
6	CHY20	Balancing valve kit

## 7.2. Hydraulic depth setting (SoftControl option)

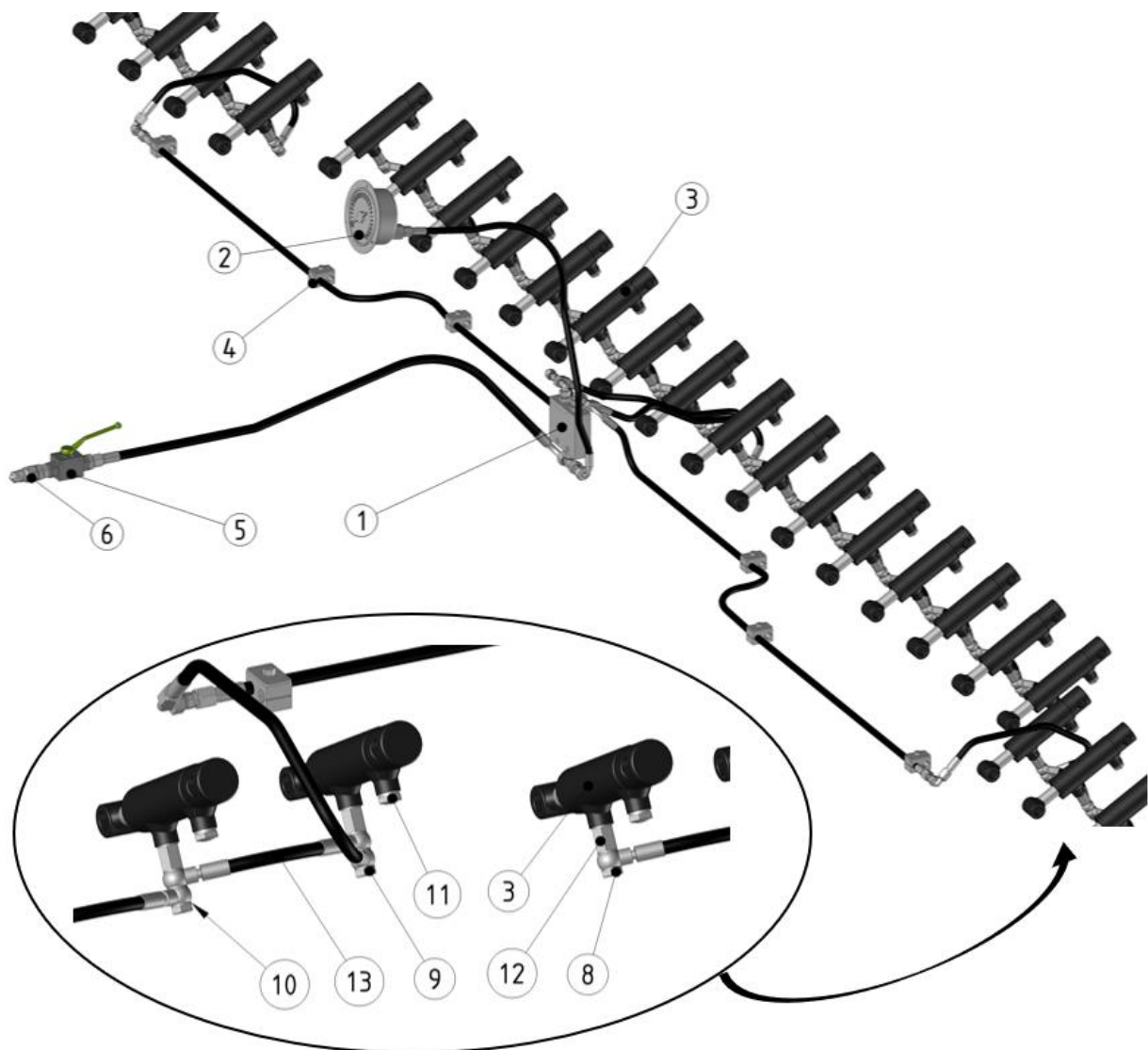

Mark	Reference	Designation
1	CHY94	Flow rate regulator
2	CHY95	Manometer
3	VH6P	Ram
4	CHY56	Clamp collar
5	CHY93	Bushel valve
6	CHY19	Male connector
8	CHY79	Hollow screw
9	CHY80	Double hollow screw
10	CHY57	Seal
11	CHY18	Breather
12	CHY81	Extension

## 8. Nomenclature

### 8.1. Linkage

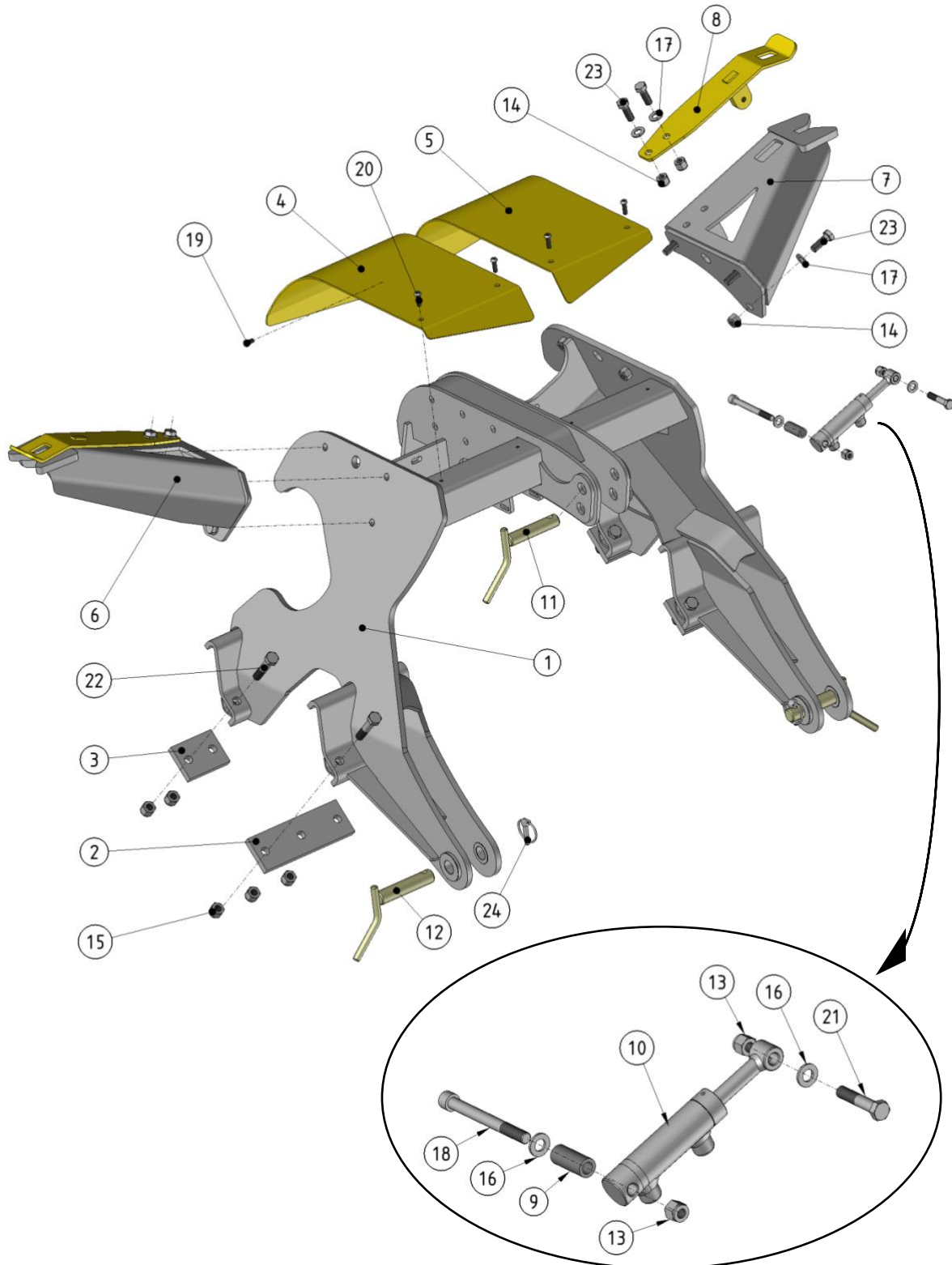

**Nomenclature : Linkage**

Mark	Reference	Designation
1	MS12P	Linkage
2	US18Z	Front flange
3	US19Z	Rear flange
4	TL7P	Right cover
5	TL8P	Left cover
6	MS13P	Lock holder
7	MS14P	Lock holder
8	TL9P	Complete spring lock
9	US21Z	Ram spacer
10	VH1P	Ram
11	DV6	Axis Ø25
12	DV7	Axis Ø28
13	BECHFR127040ZN	Nut
14	BECHFR147040ZN	Nut
15	BECHFR167040ZN	Nut
16	BRD127089ZN	Washer
17	BRD147089ZN	Washer
18	B12X120476288	Screw
19	BTB8X1673801	Screw
20	BTB8X2573801	Screw
21	B12X60401488	Screw
22	B16X80401488	Screw
23	B14X40401788	Screw
24	DV31	Spring pin clips

## 8.2. Châssis

Chassis	Arms	Extensions	Overall width
2.84m	1.74m	/	4.80m
2.84m	1.74m	0.80m	6.40m

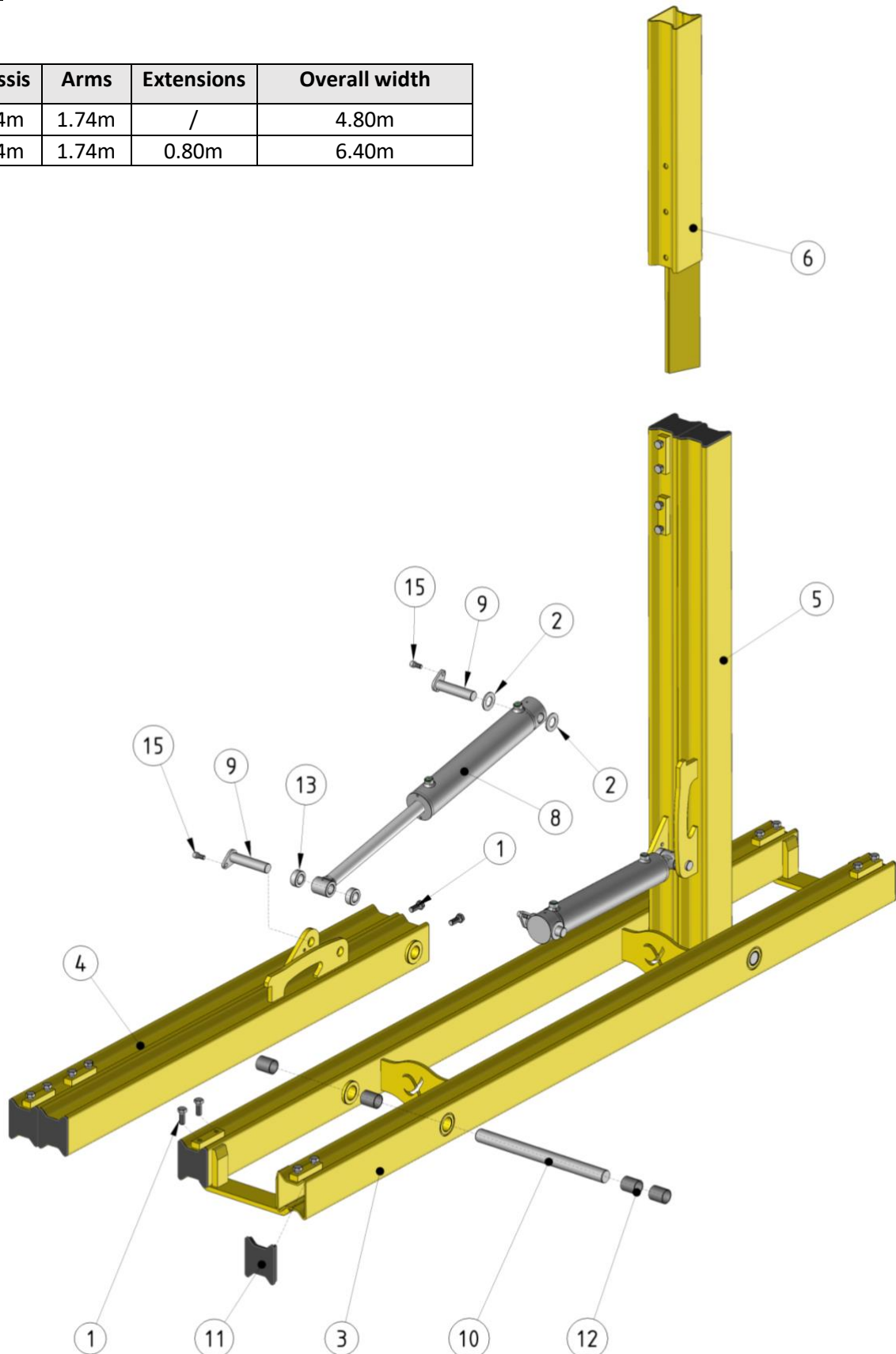

**Nomenclature : Châssis**

Mark	Reference	Designation
1	B16X40401788	Screw
2	BRD307089ZN	Washer
3	TU1P	Chassis 2.84m
4	TU2P	Right arm 1.74m
5	TU3P	Left arm 1.74m
6	TU4P	Extension 0.80 m
8	VH2P	Ram
9	US24Z	Axis
10	US23B	Axis
11	DV9	Capping
12	DV8	Bushing
13	US25Z	Ram spacer
15	B12X25476288	Screw

### 8.3. Gauge wheels

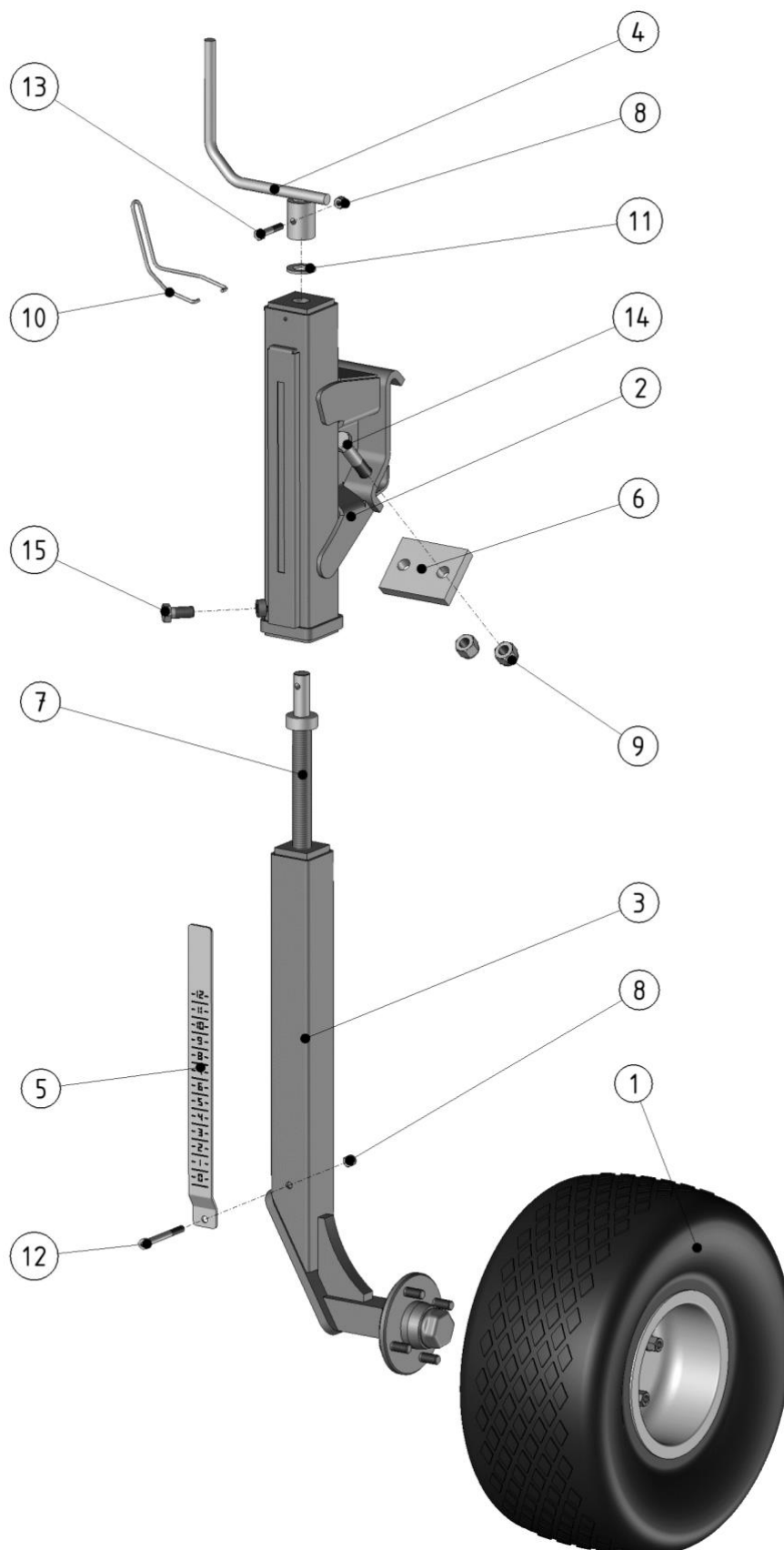

**Nomenclature: Gauge wheels**

Mark	Reference	Designation
1	DV10	Wheel 18.5 x 8.50 x 8
2	MS15P	Left gauge wheel fitting
	MS16P	Right gauge wheel fitting
3	MS17P	Wheel holder
4	US26Z	Handle
5	TL10Z	Graduation
6	US19Z	Rear flange
7	US27Z	Depth setting screw
8	BECHFR87040ZN	Nut
9	BECHFR167040ZN	Nut
10	PF3Z	Handle spring
11	BRD207089ZN	Washer
12	B8X80476288	Screw
13	B8X45401488	Screw
14	B16X80401488	Screw
15	B14X30401788	Screw

## 8.4. Hoeing elements

### 8.4.1. Hoe's arm

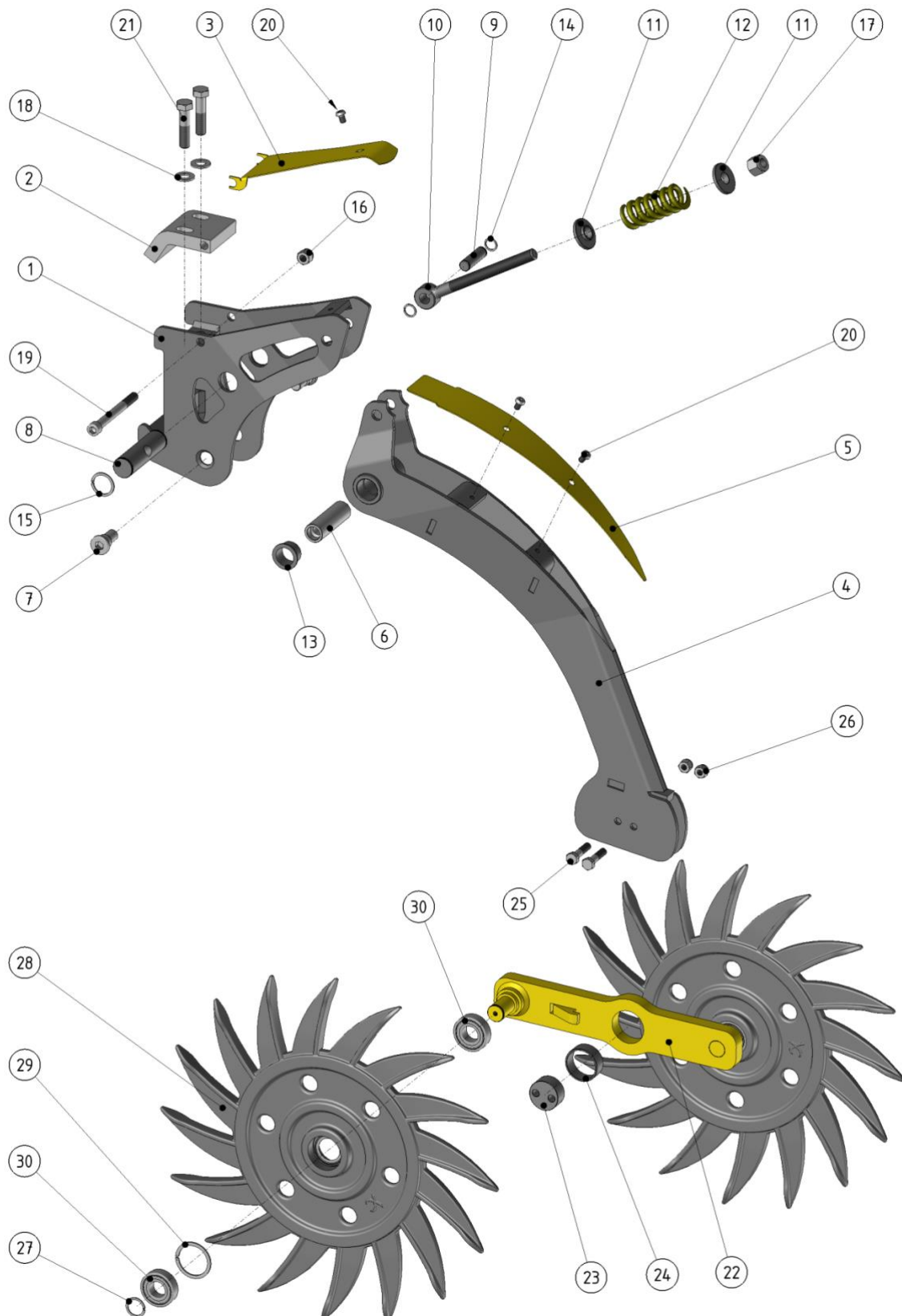

**Nomenclature : Bras de hou**

Mark	Reference	Reference	DESIGNATION
1		MS9P	Hoe box
2		US9Z	Stopper
3		TL6P	Box cover
4		MS65P	Hoe's arm
5		TL5P	Arm cover
6		US7Z	Spreader bush
7		US8Z	Spreader screw
8		US15Z	Spring guide
9		US14Z	Axis
10		US17Z	Eye rod M16
11		US57Z	Spring washer
12		PF6Z	Loader spring Ø8 Wire
13		DV2	Skirt bushing
14		BAEEXT16471	External snap ring
15		BAEEXT30471	External snap ring
16		BECHFR127040ZN	Nut
17		BECHFR167040ZN	Nut
18		BRD147089ZN	Washer
19		B12X120476288	Screw
20		BTB8X1273801	Screw
21		B14X60401488	Screw
22	SE12P	MS11P	Beam
23		US13Z	Beam spacer bush
24		DV4	Bushing
25		B10X45401488	Screw
26		BECHFR107040ZN	Nut
27	SE20P	BAEEXT25471	External snap ring
28		PU1P	Star-wheel
29		BAEINT52472	Internal snap ring
30		DV59	Waterproof ball-bearing

8.4.2. Comb support

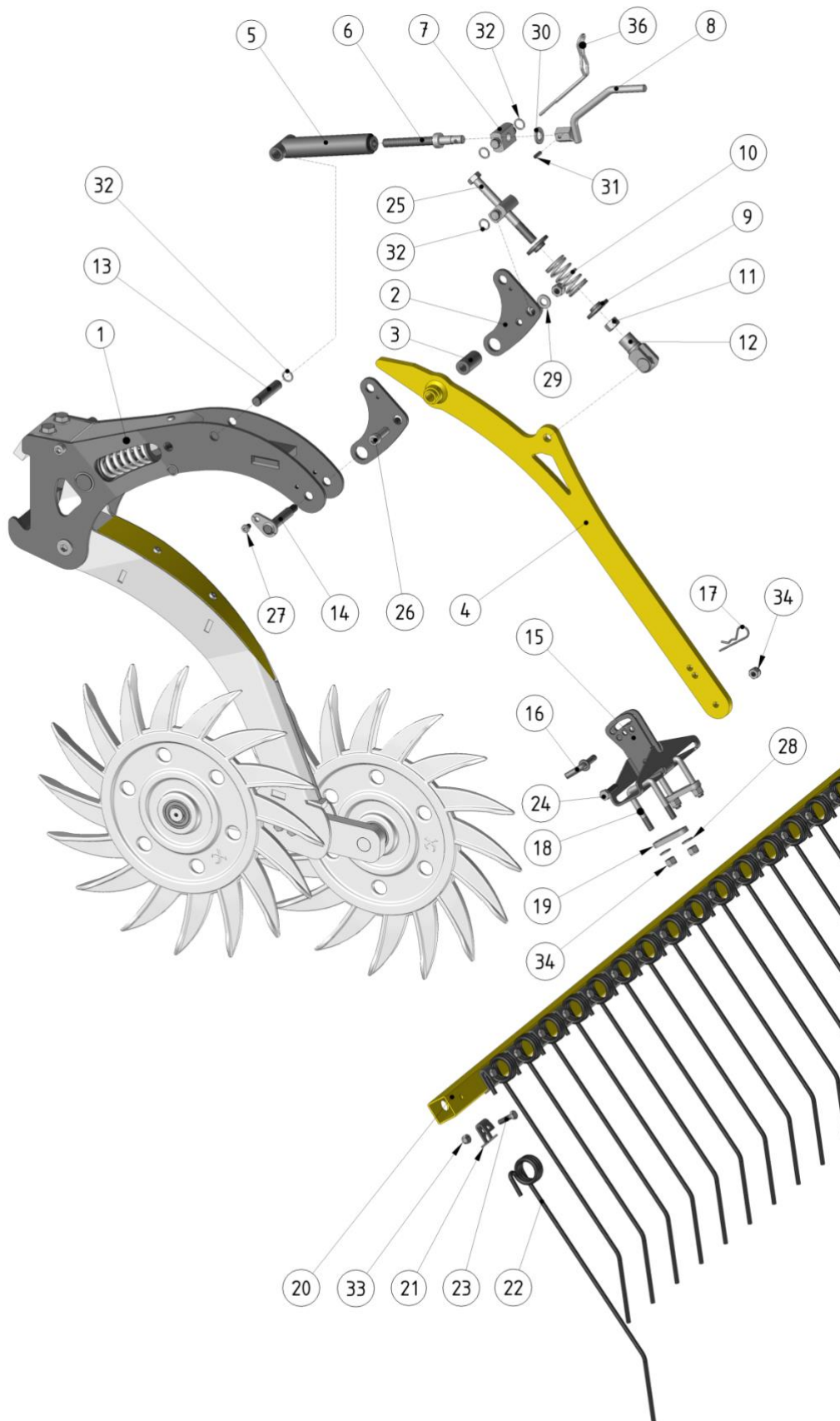

**Nomenclature: Comb support**

Mark	Reference	Designation
1	MS38P	Hoe's box with comb support
2	US42P	Comb pressure setting side plate
3	US66Z	Comb pressure tilting spacer
4	MS39P	Comb arm
5	MS41P	Pressure setting shaft
6	US67Z	Depth setting screw
7	US65Z	Hub
8	US67Z	Comb handle
9	US57Z	Spring washer
10	PF5Z	Loader spring Ø5.6mm Wire
11	BECHFR147040ZN	Nut
12	DV54	Rod system's yoke
13	US63Z	Body axle
14	US64Z	Comb arm axle
15	MS40P	Tube flange
16	US53Z	Comb setting axle
17	BGB3X67	Ø3 Spring pin
18	DV55	Comb flange bracket
19	TL28Z	Jumper flange
20	TU15P	Comb tube 89cm
	TU6P	Comb tube 179cm
	TU7P	Comb tube 278cm
21	US55Z	Comb tooth clamp
22	TZP93394	Comb tooth Ø7
23	B8X30401488	Screw
24	B10X35401788	Screw
25	B14X140401488	Screw
26	B12X80476288	Screw
27	BTB8X1273801	Screw
28	BRD107089ZN	Washer
29	BRD127089ZN	Washer
30	BRD147089ZN	Washer
31	BGEEP6X228752	Pin
32	BAEEXT16471	Snap ring
33	BECHFR87040ZN	Nut
34	BECHFR107040ZN	Nut
35	BECHFR127040ZN	Nut
36	PF3Z	Handle lock spring

### 8.5. Road lighting equipment

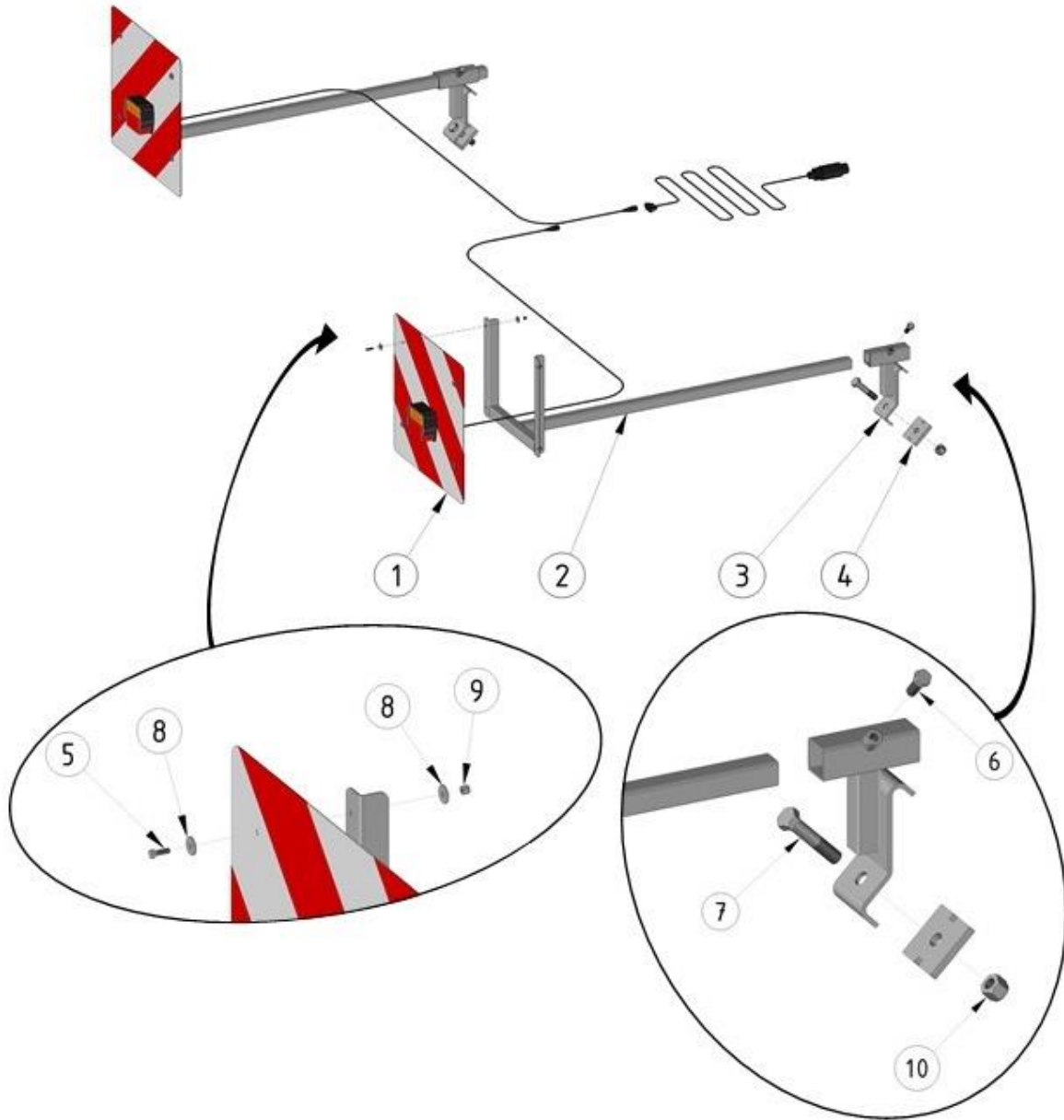

**Nomenclature: Road lighting equipment**

Mark	Reference	Designation
1	DV45	Plates kit with lamp and wires
2	MS67P	Long plate holder
3	MS66P	H-beam plate holder bracket
4	US52Z	Holder flange
5	B5X16401788	Screw
6	B12X35401788	Screw
7	B16X80401488	Screw
8	BRD057089ZN	Plain washer
9	BECHFR57040ZN	Nut
10	BECHFR167040ZN	Nut

## 9. Notes





**B.C TECHNIQUE AGRO-ORGANIQUE S.A.S.**

**Bois Choppard**

**F – 89270 VERMENTON**

**Tel. : +33 (0)3 86 34 31 64**

**@: [commercial@bc-technique.com](mailto:commercial@bc-technique.com)**