

ROW HOE

Onyx



B.C. TECHNIQUE AGRO-ORGANIQUE S.A.S.

Contents

1. Conformity statement and device identification.....	5
--	---

1.1.	Conformity statement.....	5
1.2.	Data plate	6
2.	General safety rules	7
2.1.	Obligations and responsibilities	7
2.2.	To do before use	7
2.3.	Description of safety symbols	7
2.4.	Warning signs	8
2.5.	Safety instructions.....	10
2.5.1	Safety instructions relevant to the machine’s setup and maintenance.....	10
2.5.2	Safety instructions for road transport	10
2.5.3	Safety instructions during the machine’s operation	11
3.	Introduction to the machine.....	12
3.1.	General information.....	12
3.2.	Row hoe coupling.....	12
3.3.	Special attachment for LYNX camera-guided interface by B.C.TECHNIQUE.....	12
3.4.	Gauge wheels	13
3.5.	Uncoupling stands.....	13
3.6.	Parallelogram and teeth-holders	13
4.	Set-up.....	14
4.1.	Tractor requirements	14
4.2.	Coupling.....	15
4.3.	Installation and connection.....	14
4.3.1	Electrical connection (depending on option)	14
4.3.2	Hydraulic connection	15
5.	General settings	16
5.1.	Foreword	16
5.2.	Chassis adjustment.....	17
5.3.	Chassis adjustment.....	18
5.3.1.	Spacing.....	18
5.3.2.	Deformable parallelogram adjustment.....	18
5.3.3.	Working depth setting	19
5.4.	Tine-holders setting	20
5.4.1.	Width setting.....	20

5.4.2.	Height setting	20
5.5.	Plant-protection discs	21
6.	Maintenance and servicing	22
6.1.	Maintenance and servicing	22
6.2.	Cleaning	22
6.3.	Instructions for storage	22
7.	Hydraulic circuit	24
7.1.	Folding with mechanical lock	24
7.2.	Folding without mechanical lock	25
8.	Nomenclature	26
8.1.	Coupling	27
8.2.	Standard chassis	28
8.3.	Wide chassis	30
8.4.	Gauge wheels	32
8.5.	Parallelogram	34
8.5.1.	Front box of parallelogram	34
8.5.2.	Rear box of parallelogram	36
8.5.3.	Locking system and forced topsoiling	38
8.5.4.	Parallelogram's gauge wheel	40
8.6.	Tine-holder elements	42
8.6.1.	Tine-holders components	42
8.6.2.	Tine-holders components	44
8.6.3.	Shear and teeth	46
8.7.	Protection disk	48
8.8.	Flexible weeder fingers	50
8.9.	Road lighting equipment	52
9.	Notes	54

Dear user,

First we would like to thank you for your confidence and hope that your HELIOS rotary hoe will give you full satisfaction.

The few minutes you will spend reading this leaflet will allow you to use the full performances of your ONYX row hoe, to save its service life and work in full safety conditions.

This user guide is an important document, keep it safe and refer to it if needed. Provide it to any other user and to the new owner, should you resell it.

Should any picture or technical data included in this document not be precisely matching your ONYX row hoe, operating conditions would however remain unchanged.



1. Conformity statement and device identification

1.1. Conformity statement



The manufacturer:

BC TECHNIQUE AGRO-ORGANIQUE
Bois Choppard
F-89270 VERMENTON

Declares the the devices:

ONYX Row hoe

Serial nr:

Fulfil the statements of directive 2006/42/CE of European parliament
and council dated May 17th, 2006 suitable to machines.

Vermenton, on : / / .

Mathias BOUNON
Chairman
B.C. TECHNIQUE AGRO-ORGANIQUE S.A.S.

1.2. Data plate



The data plate is a dark grey rectangular label. At the top center is the PHENIX AGROSYSTEM logo, featuring the word 'PHENIX' in a bold, sans-serif font with a stylized yellow and white starburst graphic to its right, and 'AGROSYSTEM' in a smaller font below it. Below the logo are four horizontal grey bars for data entry, each preceded by a label in French and English: 'Désignation / Type :', 'N° de série / Serial number :', 'Poids / Weight :', and 'Année / Year :'. At the bottom left, the text 'Bois Choppard F-89270 VERMENTON' is printed. At the bottom right is the CE mark.

Appear on this plate designation and serial number both required for any request of information, spare parts or technical support.

2. General safety rules

2.1. Obligations and responsibilities

These instructions should be considered only as guidelines, and non-binding, in any case for neither BC TECHNIQUE's nor its representative's responsibility. The entire responsibilities of operation, road transportation, maintenance and servicing lies with owners and operators.

The owner and operator are entirely liable for the correct operation of the device in every respect. The owner is also responsible of ascertaining the staff operating the device read and understood these instructions and works in accordance with regulations and provisions in force.

Should one of the device's operators find out a breach of security rules, this must be addressed immediately.

Prior to delivery, every machine is submitted to quality inspection and tries in operation. However, the operator/owner remains fully liable of of the device's proper operation in the field.

Modifications applied to the machine's design are part of our continuous improvement process. The machine's description apply to its configuration at the time of this leaflet's writing. The user guide may include pictures showing a machine that does not match exactly yours, depending on model, options or performed upgrades.

2.2. To do before use

-Carefully read these instructions and make sure their content being understood.

-Learn to operate properly the machine, keeping prudent.

If operated by an untrained operator, or neglectfully used, the machine may turn out to be hazardous.

The machine will be part of the user and colleague's workplace. Therefore, care has to be taken of everyone's safety and of proper use of individual protection equipment.

2.3. Description of safety symbols



Always pay particular attention to instructions or diagrams highlighted by this symbol. This symbol warns against a deathly hazard, serious physical injuries or important material damage should no action being taken to avoid it.



This symbol calls to a particular situation or required action to ensure proper use of the machine. Breaching these instructions may result in issues affecting either the machine or its surroundings.





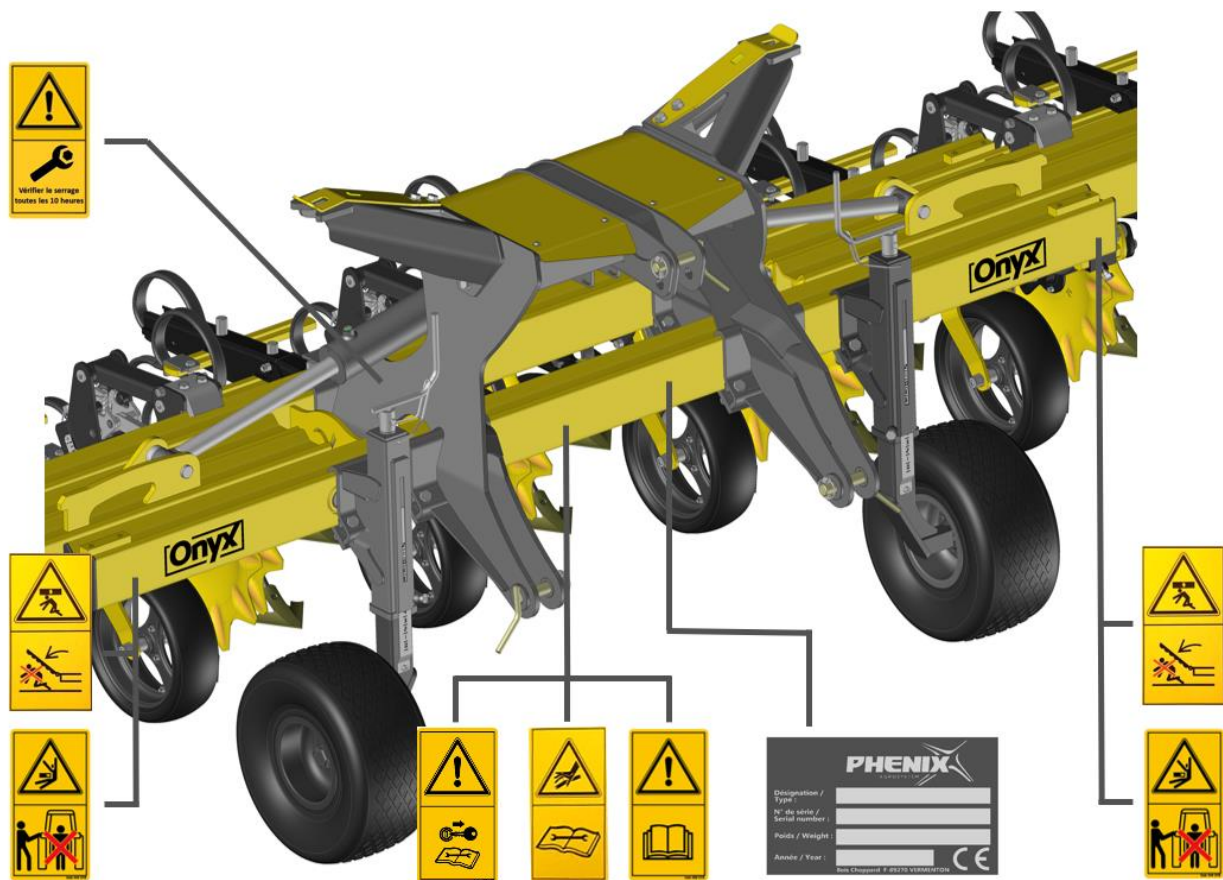

Information involved in this symbol are of interest, because they offer advice or particularly useful information about the proper operation of the machine.

2.4. Warning signs







	<p>Prior to putting the machine into use, please read the user guide and fulfil the safety instructions its states.</p>
	<p>Be regularly checking the working parts tightening. Fulfilling this instruction will held you avoiding:</p> <ul style="list-style-type: none"> • The falling of elements able to harm your safety. • The loss of parts (out of warranty) • The deterioration of your machine



	<p>Risk of crushing due to machine's parts in action ! This may cause extremely serious injuries. Stay away from equipment tilting. Avoid anyone remaining in this dangerous zone as long as the tractor's engine is running and hydraulic and electronic systems are into action.</p>
	<p>Risk of injury by contact with high pressure hydraulic fluid leaking, due to hydraulic hose's sealing defect. High pressure hydraulic fluid jet leaking may penetrate the skin and result in extremely serious or lethal injuries.</p> <ul style="list-style-type: none"> • Never be trying under any circumstance to plug a hydraulic hose leak with fingers or hands. • Please read and fulfil safety instructions from the user guide leaflet prior to proceeding in any servicing or repairing hydraulic hoses. • Should such injury happen, immediately consult a doctor.
	<p>Risks of crushing between the tractor's back and the machine when coupling or uncoupling it. This may cause extremely serious injuries or death.</p> <ul style="list-style-type: none"> • It is forbidden to activate the tractor's 3-points hitch hydraulic circuit as long as people stand between the tractor's back and the machine. • Action levers of the 3-points hitch should be actioned <ul style="list-style-type: none"> - only from the working zone dedicated to that purpose - never, under any circumstance, when you are standing in the hazard zone between the tractor and the machine.
	<p>Hazardous situations for the operator when taking action to the machine, for example when mounting, setting up, troubleshooting, cleaning, servicing or repairing, due to the machine's inadvertent start or move! Possible risk may result in severe body injuries and death.</p> <ul style="list-style-type: none"> • Prior to any action on the machine, have every measures taken to prevent inadvertent start or move. • Regarding the type of action to be taken, read and fulfil the instruction of the relevant chapter of this user guide leaflet.

2.5. Safety instructions



2.5.1 Safety instructions relevant to the machine's setup and maintenance

	<p>Always park the device on a plain and steady ground.</p>
	<p>The machine is featured with a hydraulic circuit, under pressure when the row hoe is coupled to a tractor. Always stop the tractor (and disconnect power source depending on option) during every repair or maintenance action taken to the row hoe.</p>
	<p>Regularly check 3-points hitch's balls and pins for wear.</p>
	<p>Prior to connecting the hydraulic hoses, always make sure the male connectors of the row hoe and the female connectors of the tractor are clean and free from dust</p>
	<p>In order to safeguard the quality and safety of the equipment, only original BC TECHNIQUE spare parts are to be used. Terms of warranty as well as any claim referring it will be void, should non-original spare parts having been used.</p>

2.5.2 Safety instructions for road transport

	<p>The entire responsibility of transport on public roads lies on the owner and driver.</p>
	<p>Having first coupled the carriage, make sure that at least 20% of the tractor's weight bears upon the front wheels. This will preserve the carriage's manoeuvrability during the drive.</p>
	<p>To avoid any hazard resulting from errors during the drive on roads, the whole electronic control equipment, either outside or inside the cabin, must be shut off before beginning to drive.</p>

2.5.3 Safety instructions during the machine's operation

	<p>When the tractor's engine is running, make sure that surrounding people stand at a sufficient safe distance from any suspended load, and from any lifted or mobile machine member.</p>
	<p>Every time there is work being done beneath the machine, or every time there is a risk of injury by crushing, the machine has to be fully and properly lifted and supported. Use some stands.</p>

3. Introduction to the machine

3.1. General information

All optional features can be subsequently mounted to the basic machine



Post-delivery assembly should be performed only by required technical-skilled staff.

3.2. Row hoe linkage

The ONYX row hoe is originally featured with standard linkage cat.II.

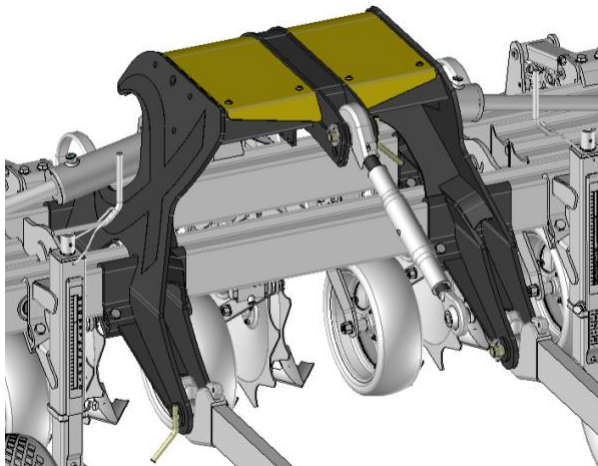

As an option, you can take advantage of an auto-locking folding system.

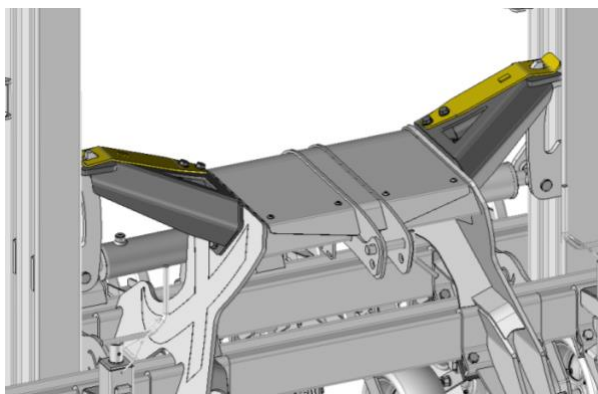

3.3. Special attachment for LYNX camera-guided interface by B.C. TECHNIQUE

This attachment has been specially designed to reduce the rear overhang. The auto-locking folding (optional) system provides an effective support to the chassis while folded for road transport.

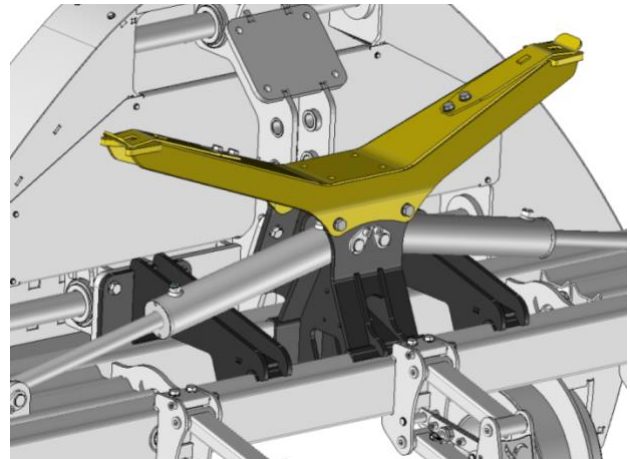

3.4. Gauge wheels

The gauge wheels are fitted with spring-lockable handles ① and graduations. A tightening screw ② allows to definitely secure the final adjustment (voir §5.2).

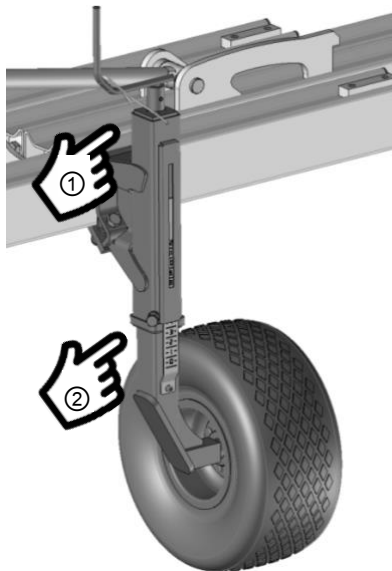

Tires pressure:

<i>Tire dimension</i>	18.5 x 8.50 - 8
<i>Recommended pressure</i>	5 bars / 73 Psi
<i>Max. pressure</i>	6.3 bars / 92 Psi

3.5. Unfitting the stands

The 2 stands ensure the stability of your row hoe when uncoupled from your tractor.

Driving on road is allowed only when the stands are off.

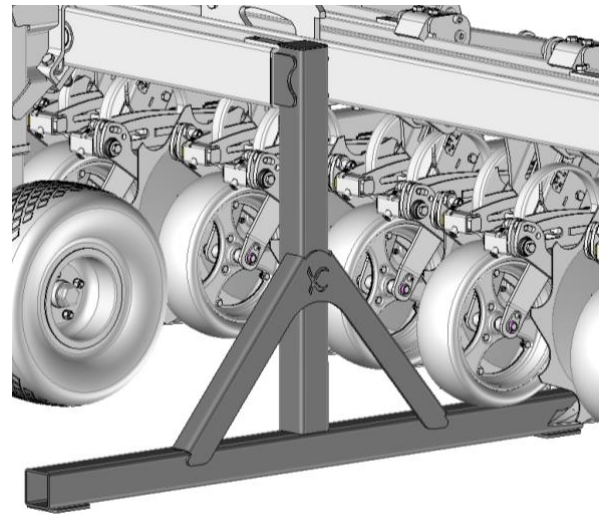

For better safety we recommend storing your row hoe unfolded on a plain and steady ground.

3.6. Parallelogram and teeth-holders

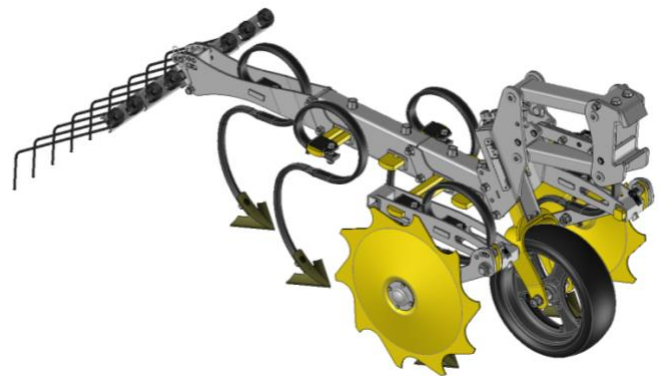

The main elements of the tilling section are:

- Forced topsoiling parallelogram
- Parallelogram's gauge wheel
- Plant-protection discs
- Vibrant or straight tines
- Rear comb harrow (option)

4. Set-up

4.1. Tractor requirements

The ONYX row hoe is featured with standard linkage cat.2 Depending on the working width (from 2.8m to 7.2m), the selected tractor should feature at least a 90 HP power.

The tractor should not be coupled to the machine if either the maximum load per axle or its specific maximum total authorized weight is exceeded.

The tractor must feature:

- a 3-points hitch cat. 2 (ou 3)
- 1 or 3 double-action hydraulic valves, depending on the device's options.

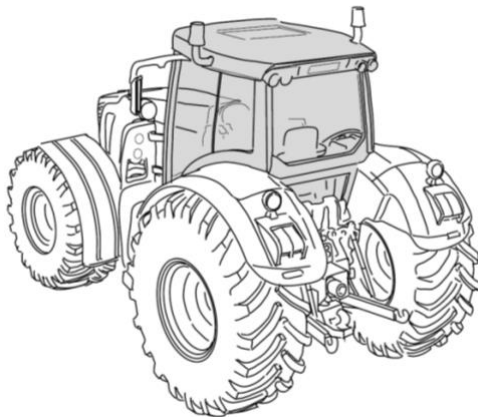

The tractor's cab should be designed to protect the operator from debris and dust which are dangerous for his health.

4.2. Hitching

1. Adjust both the tractor's hitch's arms so they stand the same height.
2. Should the tractor feature quick-hitching hooks (recommended) adjust the width between the hitch's arms so the optimal center distance of 875mm is fulfilled.

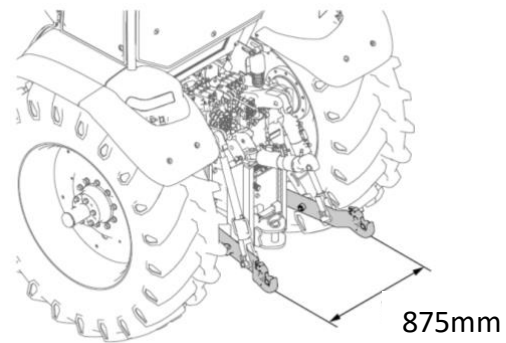

3. Drive in reverse gear till the tractor comes about one meter away in front of the hoe's linkage points Engage the tractor's parking brake
4. Connect the hydraulic hoses and electric cables.
5. Drive one more meter backwards to the linkage points.



Nobody has to be standing between the tractor and the rotary hoe during the tractor's reverse drive.

6. Couple the row hoe's three points to the tractor's.
7. Lift the machine
8. Have the stands off.

4.3. Installation and connection

4.3.1 Electrical connection (depending on option)



Prior to boring an attachment hole in the tractor's cabin, make sure there is no concealed cable at the drilling spot.

Do not invert polarity

Having this connection properly made is important in order to prevent any malfunction due to eventual faulty wiring.

Check that the machine's connection cable is not pinched under the tractor's rear window pane.

Unplug the power when the machine is out of the field.

4.3.2 Hydraulic connection

Connect the hydraulic hoses to the tractor's hydraulic connectors. Carefully check that all hoses are properly connected to the relevant hydraulic connector.



Carefully clean connectors and adaptors. This will prevent a lot of issues, as well as early wear of the hydraulic circuit.

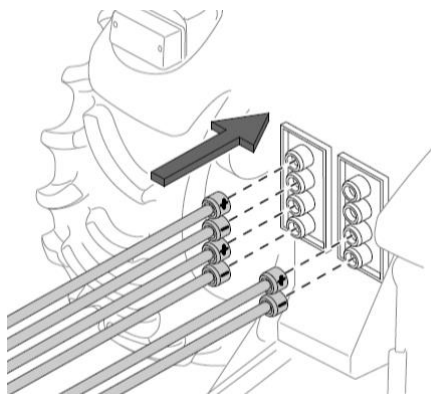

5. General settings

5.1. Foreword

Further that letting you take advantage of the quality of its equipment, B.C. Technique Agro-organique is able to provide you with advice for your agronomic operations.

The ONYX row hoe comes with either a fixed 3-points or a LYNX Interface linkage (option) LYNX interface provides auto-guidance when operating in the field, thanks to a color-scanning system and/or feelers. The machine recognizes the crop rows and steers the hoe to follow them.. This system allows **operating speed from 3 up to 13 km/h.**

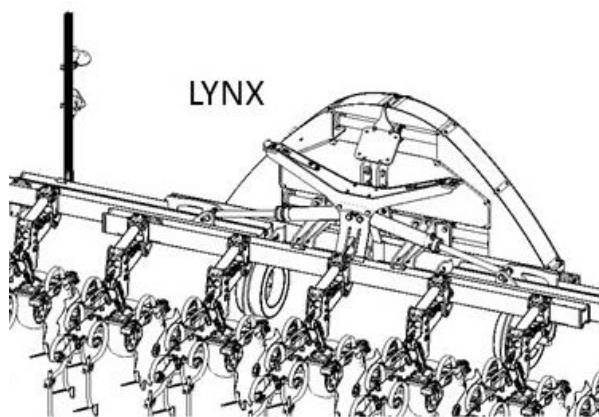

Notice that working speed must be adjusted regarding the crop stage. The younger the crop, the slower the speed must be to avoid destroying plants.

The working depth may be modified by adjusting each of the parallelograms gauge wheels. **An average 2-to-3cm-deep scalping** will provide you with the best results.



We recommend:

For better performance we advise to :

- Have a ground free from large debris or pebbles.
- Have a neat seeding done (straight-lined, regular-spaced)
- Operate the seeding with a drill of your hoe's same number of rows.
- Adjust the settings regarding the crop and its growth stage
- Check the hoe's plumb (adjustment of 3-points and lifting links)
- Operate on early weeds and crops to ensure better results (crop covering and stifling effect, favoured)
- Operate on dry soil condition and post-operation weather. Weeding will be effective and effect on the soil big.
- Operate at hottest times of the day (weeds more effectively drying)



We do not recommend:

- . Weeding too deep It may result in new seeds emerging.
- . Operate under too moist or too dry conditions

5.2. Chassis adjustment

- Having the machine unfolded and landed on a plain ground, adjust first the tine-holders level parallel to the ground using the tractor's top link's arm length.

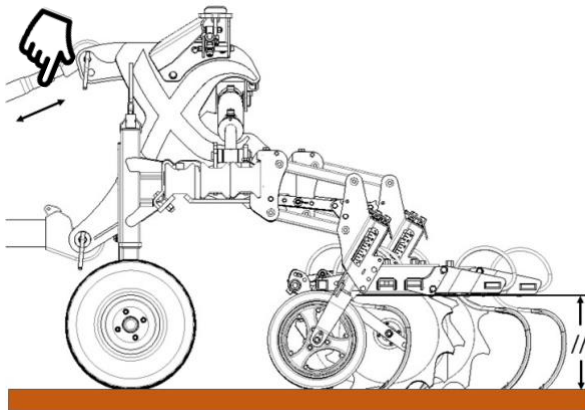

- Adjust the stabilizer links to prevent side shifts of the tractor's hitch arms.

- Using the front gauge-wheels handles, adjust the chassis height so the parallelograms will operate at a 5-15-degree angle. Graduations will allow a right similar setting of both gauge-wheels.

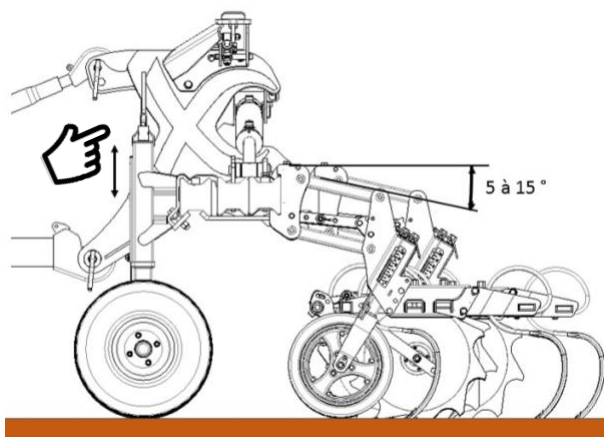

- The row hoe is featured as standard with two gauge wheels (fixed 3-points version). Their track-width has to be adjusted to fit the tractors track and till between two of your crop's rows.

To make this setting:

- . Unscrew the screws of each wheel-holder
- Slide the wheel-holder on the chassis tube profile and place it at the intended track's width.
- Tighten the wheel-holder's screws again .

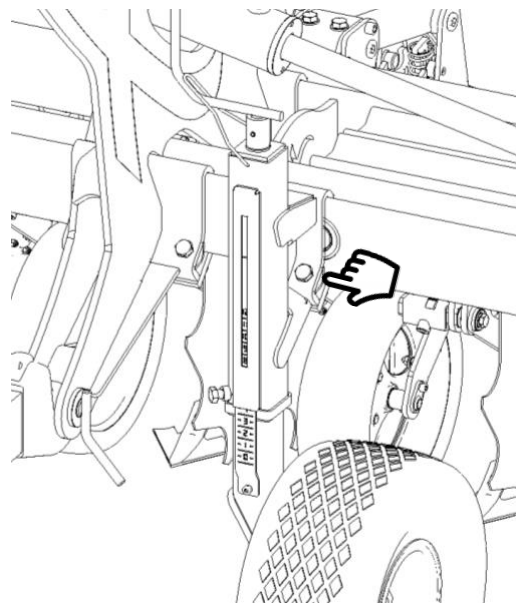

5.3. Parallelograms adjustment

5.3.1. Spacing

Parallelograms are fitted to the chassis with clamp jaws.

Spacing between parallelograms is adjustable and must match your seeding drill's inter-row.

To make this setting, begin with the centre of your row hoe and go on both sides as follows:

- Unfasten the 2 screws that fit the parallelograms to the beam.
- Slide the parallelograms on the chassis tube profile and place them at the intended spacing.
- Fasten the 2 screws again.

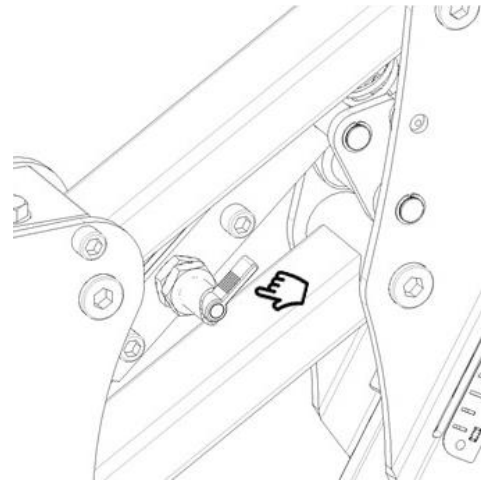
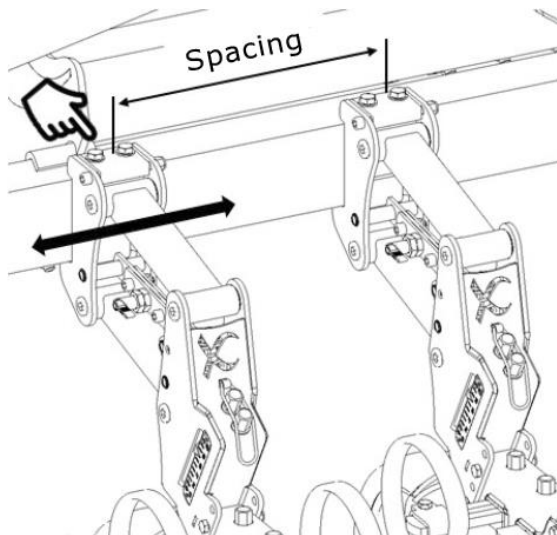

Floating position

Rotate the lever to the notch's position to set the locking free. The parallelogram turns floating and will follow the ground's relief.

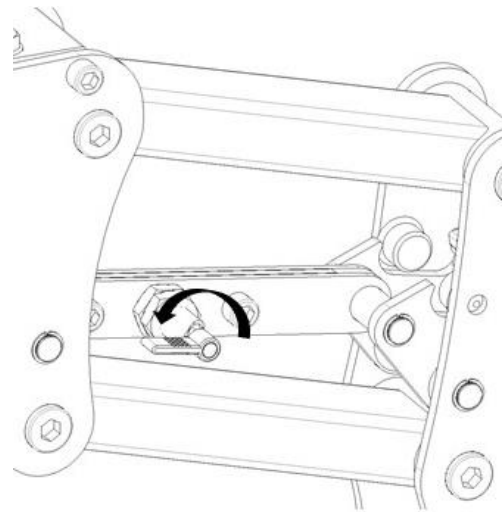

5.3.2. Deformable parallelogram adjustment

Different situation are possible:

Transport position

Lift the parallelogram by hand until it locks itself in upper position. (Pin lock on)

Forced topsoiling position

To turn into forced topsoiling mode, slightly lift your hoe with your tractor’s hitch, then lower the parallelogram by hand until it locks itself in lower position.

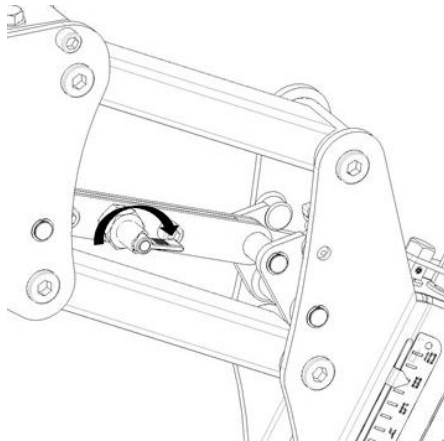

When the parallelogram is locked in lower position, you can take action on the ground pressure setting screw.

Fold back the screw’s lock when done.

This system allows your hoe to operate under hard or staking soil conditions.

A pointer and graduation helps you having the very same setting done to the other parallelograms.

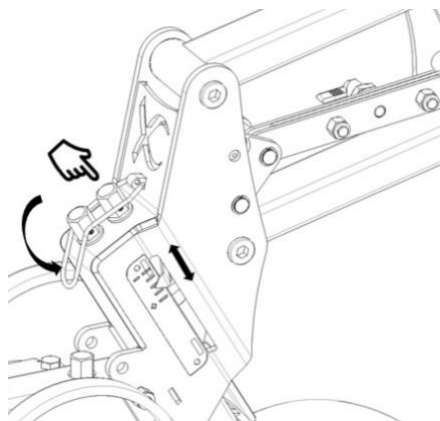

Tips and tricks: Slightly increase the ground pressure set to the elements located behind the tractor’s wheels tracks. (Compacted areas)

Hydraulic parallelograms version

B.C. Technique offers an optional hydraulic parallelograms system. Parallelograms are hydraulic-controlled one-by-one from the cab, via manual control box or via GPS control. This optional equipment can be fitted on row hoes on duty.

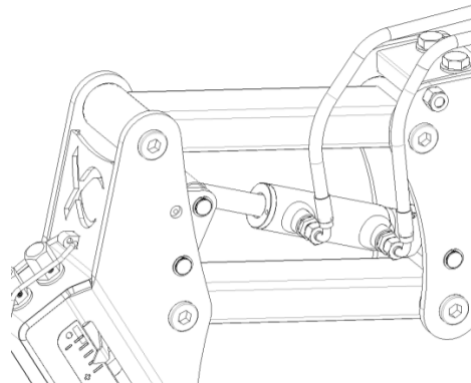

5.3.3. Working depth setting

Adjust the working depth of hoeing elements taking action to the setting screw as indicated below. Fold back the screw’s lock when done.

A pointer and graduation (0 to 10cm) helps you having the very same setting done to the other parallelograms.

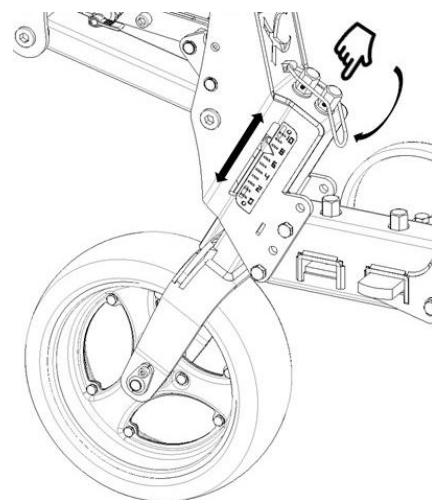

5.4. Tine-holders setting

B.C. TECHNIQUE offers a large choice of components allowing the fitting of the hoeing elements to your seeding width and row spacing. (See §nomenclature)

5.4.1. Width setting

- Release the slider's screws.
- Position the sliders at the intended width.
- Tighten the screws again with 130 Nm tightening torque

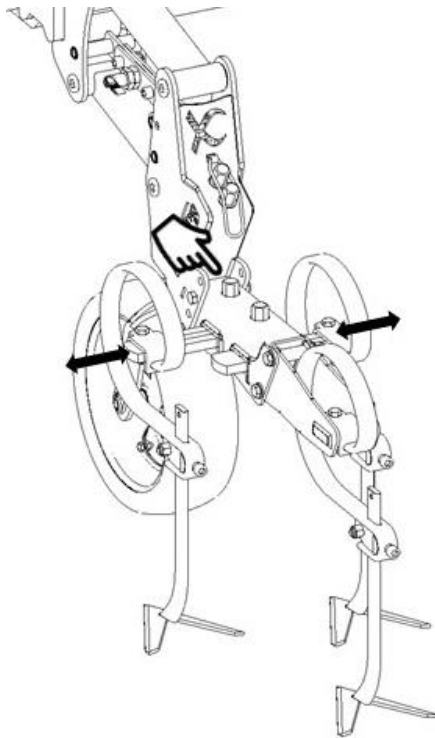

5.4.2. Height setting

A- Your hoe is fitted with vibrant tines

The flexible tines (called 'vibro' tines) are not adjustable in height. The ONYX hoe features a depth setting at the hoeing element level.

Configuration mini:

- The tines operate at the same level.

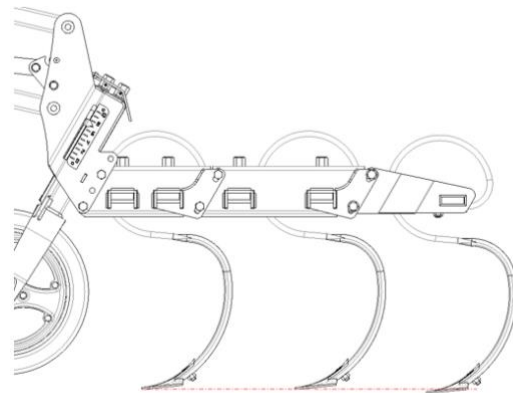

Configuration maxi:

- Intermediate tines operate 1 cm lower than front tines.
- Rear tines operate 2 cm lower than front tines.

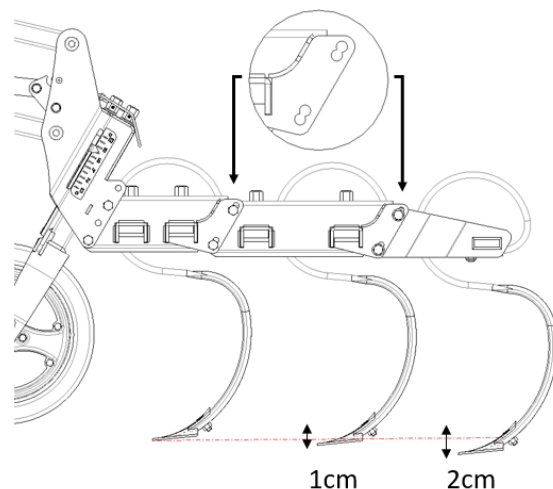

B- Your hoe is fitted with straight tines

Each tine is individually adjustable by taking action to the flange ① and the rear stopper-screw ②.

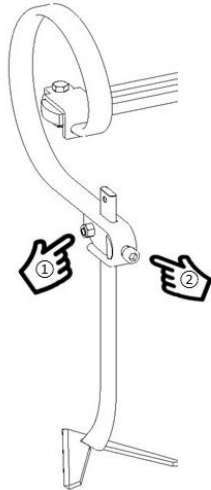

To stabilize your row hoe, we suggest you set the rear centre tines of each tine-holder 1 cm deeper.

5.5. Plant-protection discs

The plant-protection discs help avoiding to eventually spread your crop with earth or pebble.

In operating position, the locker pin should be placed in the cut-out allowing the discs to follow the relief.

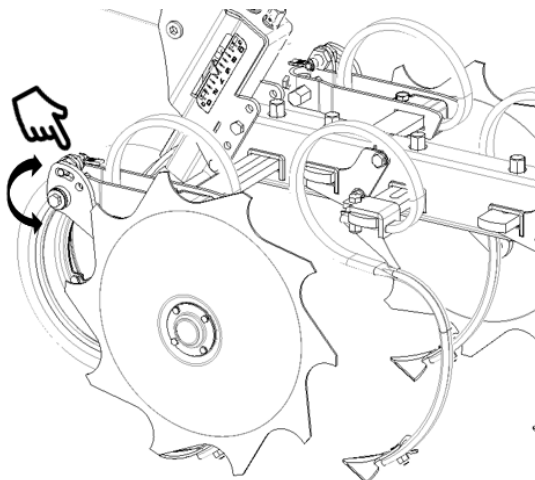

The spreads coming from the shears should be withheld by the discs.

Depending on the shape and size of the fitted shears, set the disc axle's position on their arms.

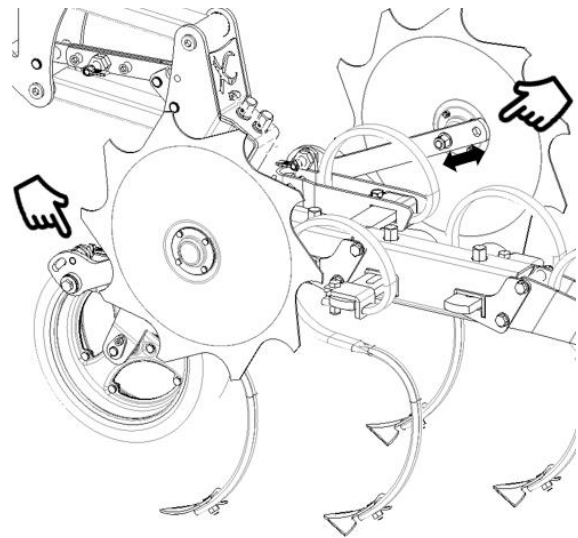

When your crops are grown enough, operation will be possible without this system. The discs may be secured in lifted position as dexribed below.

6. Maintenance and servicing

Please fulfil the storage, maintenance and servicing instructions stated below so you make sure your devices remain in perfect operating condition.

6.1. Maintenance and servicing

Prior to using your row hoe:

- Check that screws and nuts are properly tightened.
- Check that hydraulic hoses and connectors are not damaged.
- Check the tires pressure.
- Check that no accretion of pebble or earth impedes the device operation.

The joints of the chassis and the parallelograms of your ONYX row hoe are fitted with maintenance-free rings.



Greasing the wheels hubs: Unfit the hubs taps and fill in grease.
Frequency: Once a year.



Ram axles greasing:
Frequency: every 50 hours.

In order to guarantee the safety of your ONYX row hoe's operation, as well as its service life, always use manufacturer's original spare parts. Fitting any other spare part the the

manufacturer's will result in voiding the warranty.



Your machine holds the CE compliance mark. Use only new and original B.C. TECHNIQUE-approved spare parts.

6.2. Cleaning

When performing the clean-up with a HP cleaner, please spare the joints, rams, rollers, bearings.

For your own safety, wear individual protection equipment (gloves, glasses, ...)

6.3. Instructions for storage

Your ONYX row hoe includes hydraulic systems, we suggest that it is to be stored in a covered dry place.

Prior to uncouple your machine, make sure the storing spot's ground is plain, clean and steady.

- Use the provided stands to stabilize the machine during and after uncoupling.
- Remove the pressure in the hydraulic circuits by actioning the tractor's controls (with engine stopped)



Never let children play around a farm machine.

7. Hydraulic circuit

7.1. Folding with mechanical lock

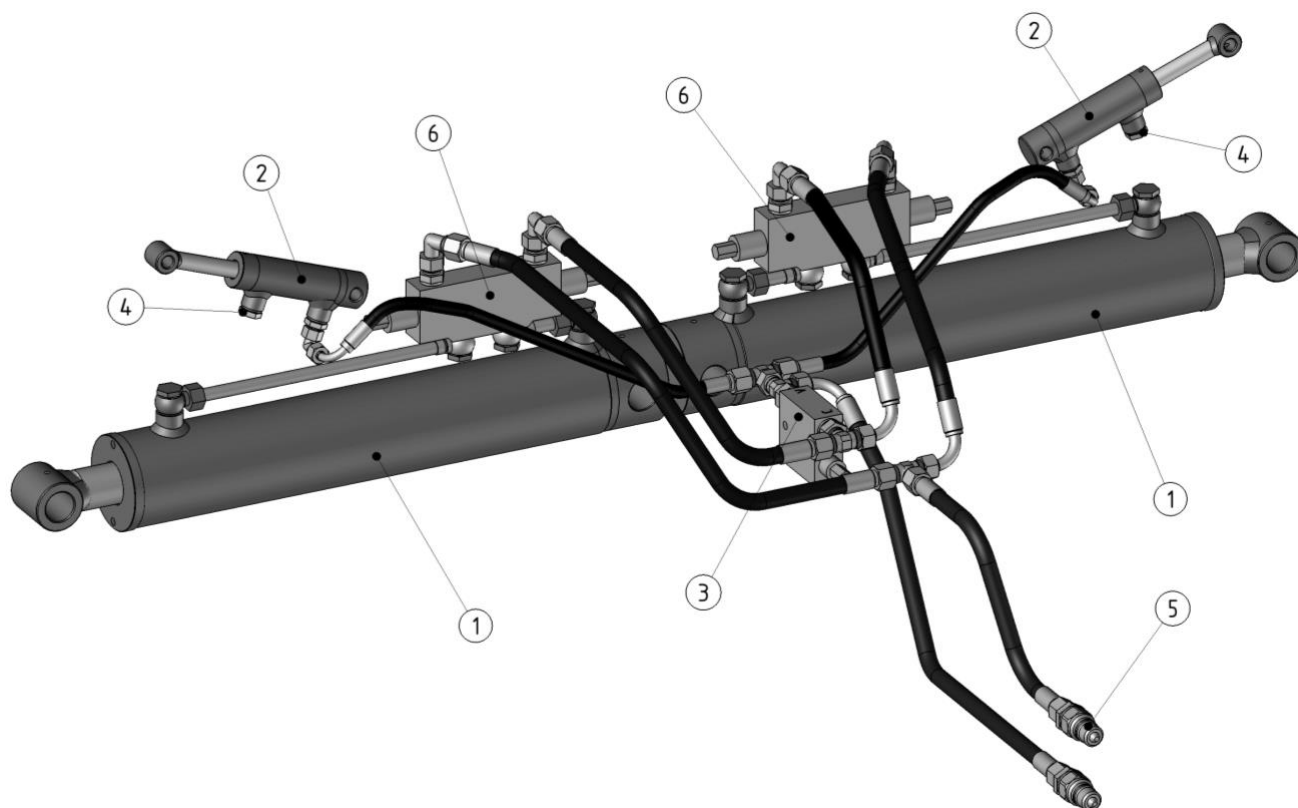

Mark	Reference	Designation
1	VH2P	Ram
2	VH1P	Ram
3	CHY17	Sequence valve
4	CHY18	Breather
5	CHY19	Male connector
6	CHY20	Balancing valve kit

7.2. Folding without mechanical lock

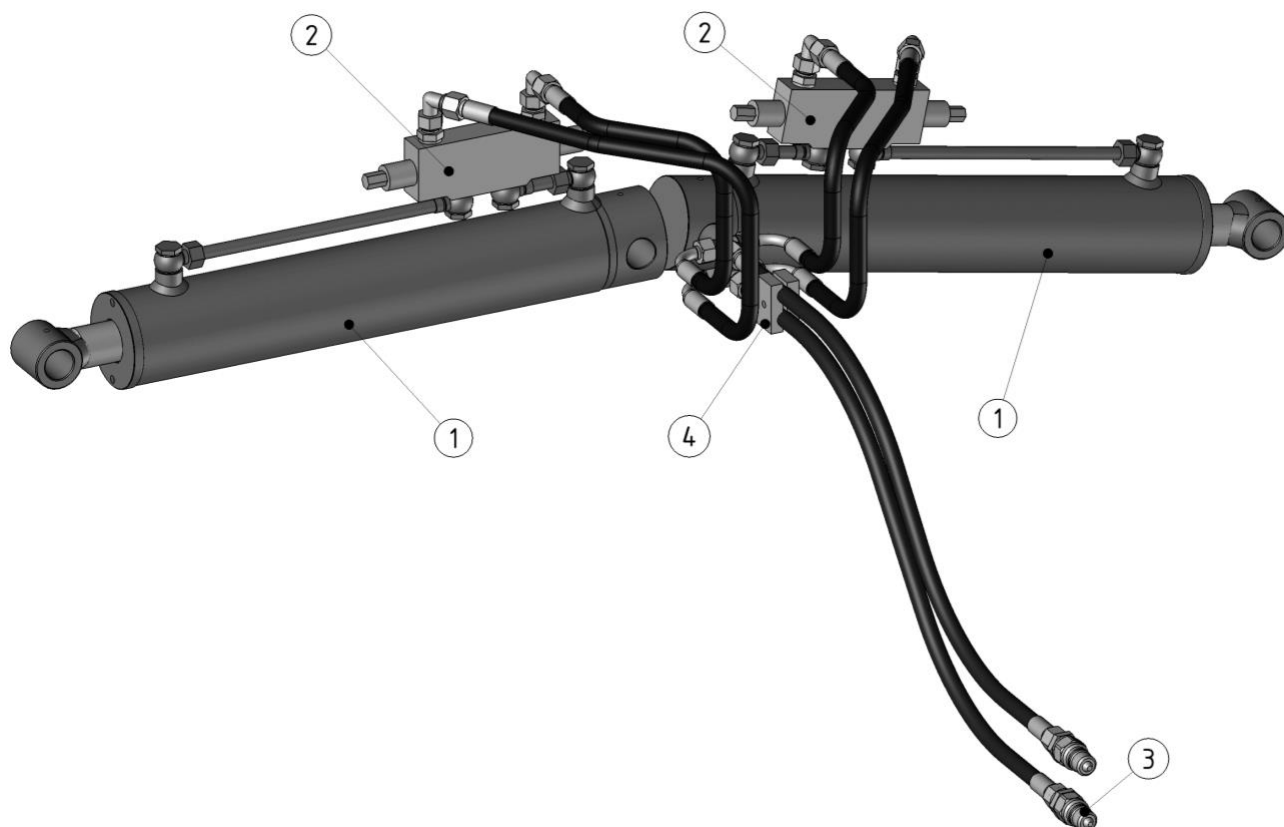

Mark	Reference	Designation
1	VH2P	Ram
2	CHY20	Balancing valve kit
3	CHY19	Male connector
4	CHY21	Hose clip

8. Nomenclature

8.1. Linkage

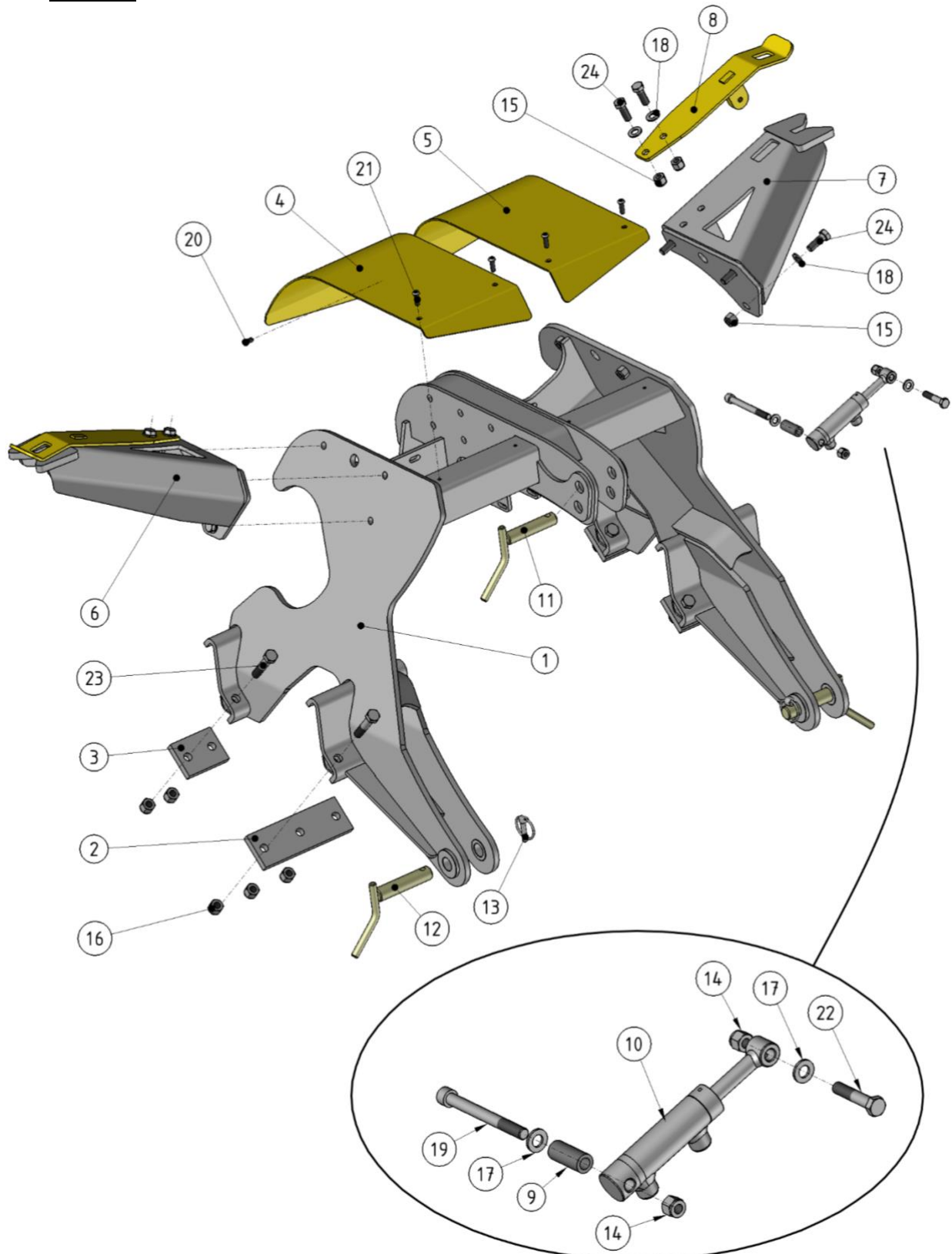

Nomenclature: Linkage

Mark	Reference	Designation
1	MS12P	Linkage
2	US18Z	Front flange
3	US19Z	Rear flange
4	TL7P	Right cover
5	TL8P	Left cover
6	MS13P	Lock holder
7	MS14P	Lock holder
8	TL9P	Complete spring lock
9	US21Z	Ram spacer
10	VH1P	Ram
11	DV6	Axis Ø25
12	DV7	Axis Ø28
13	DV31	Spring pin clips
14	BECHFR127040ZN	Nut
15	BECHFR147040ZN	Nut
16	BECHFR167040ZN	Nut
17	BRD127089ZN	Washer
18	BRD147089ZN	Washer
19	B12X120476288	Screw
20	BTB8X1673801	Screw
21	BTB8X2573801	Screw
22	B12X60401488	Screw
23	B16X80401488	Screw
24	B14X40401788	Screw

8.2. Standard chassis

Chassis	Arms	Extensions	Overall width
2m84	1m74	/	4m80
2m84	1m74	0m80	6m40
2m84	1m74	1m45	7m70

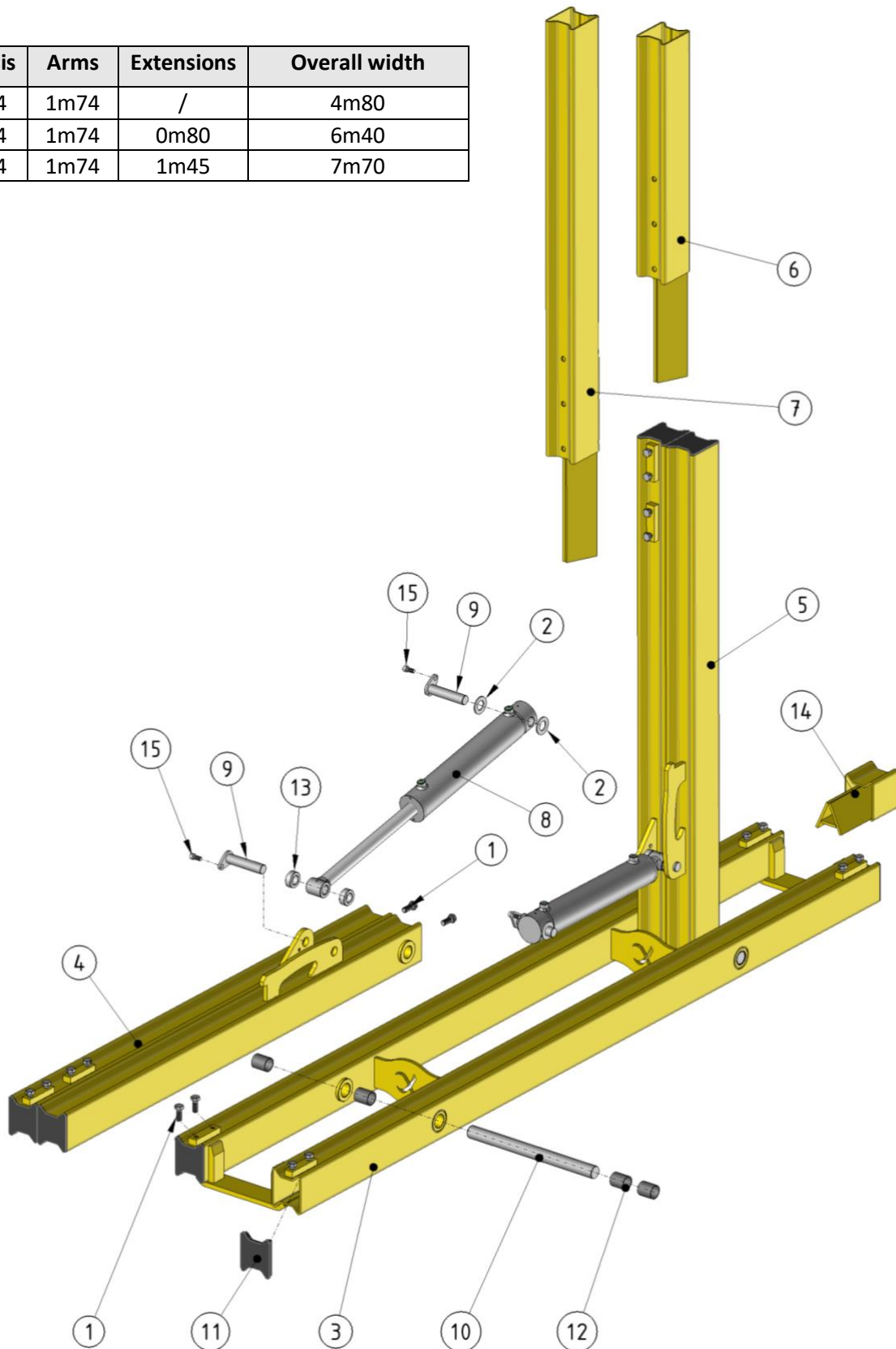

Nomenclature: Standard chassis

Mark	Reference	Designation
1	B16X40401788	Screw
2	BRD307089ZN	Washer
3	TU1P	Chassis 2.84m
4	TU2P	Right arm 1.74m
5	TU3P	Left arm 1.74m
6	TU4P	Extension 0.80 m
7	TU5P	Extension 1.45 m
8	VH2P	Ram
9	US24Z	Axis
10	US23B	Axis
11	DV9	Capping
12	DV8	Bushing
13	US25Z	Ram spacer
14	TU8P	Extension 120 mm
15	B12X25476288	Screw

8.3. Wide chassis

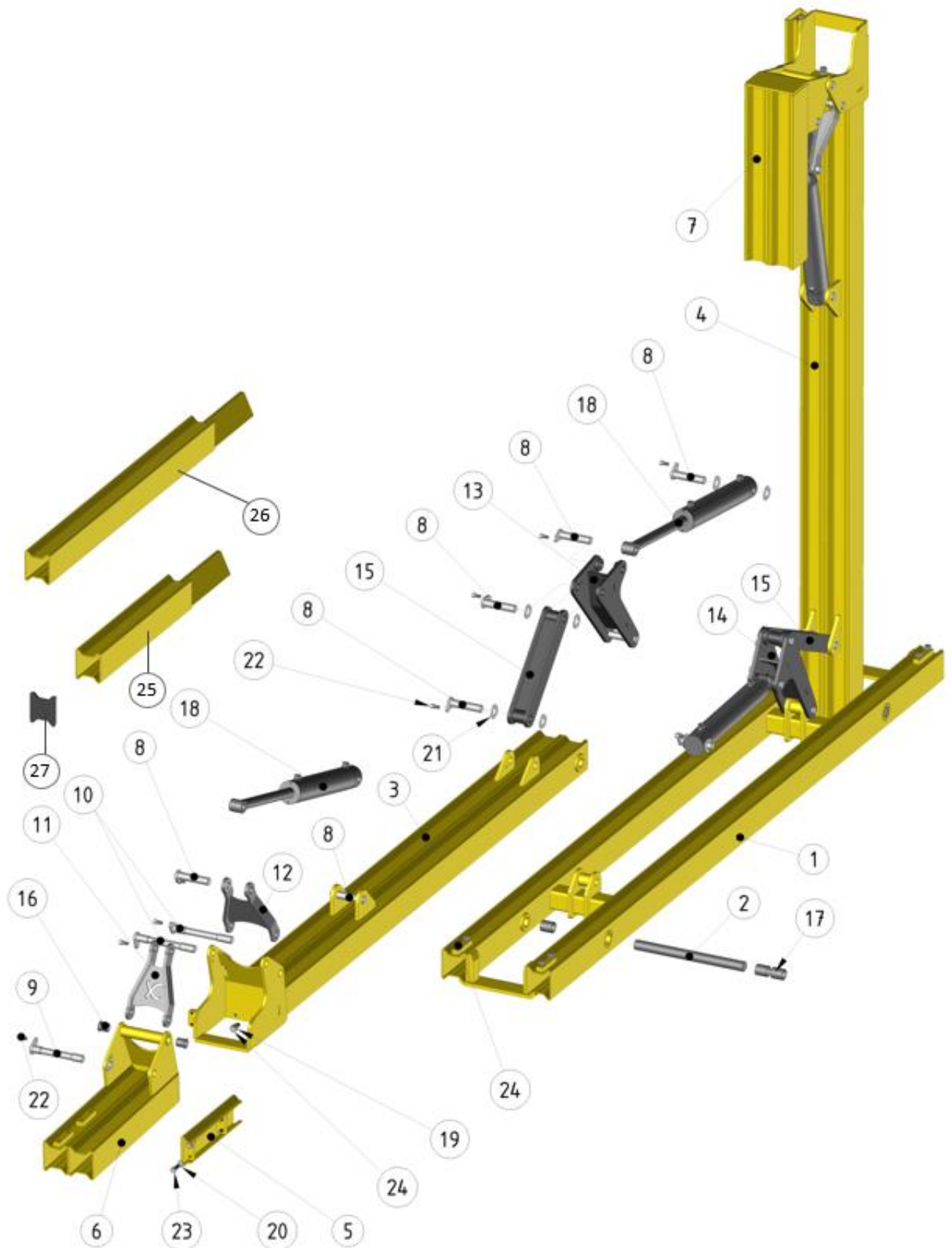

Nomenclature: Wide chassis

Mark	Reference	Designation
1	TU9P	Chassis 3.45m
2	US23B	Axis
3	TU10P	Right arm 2.73m
4	TU11P	Left arm 2.73m
5	TU14P	Rear support
6	TU12P	Right folding beam
7	TU13P	Left folding beam
8	US24Z	Ø30 x 145 axle
9	US61Z	Ø30 x 230 axle
10	US62Z	Ø30 x 265 axle
11	MS77P	Narrow connecting rod
12	MS78P	Wide connecting rod
13	MS73P	Right tipping rod
14	MS74P	Left tipping rod
15	MS75P	Deflection rod
16	DV56	Skirt bushing
17	DV8	Bushing
18	VH2P	Ram
19	BECH164032ZN	Nut
20	BRD147089ZN	Washer
21	BRD307089ZN	Washer
22	B12X25476288	Screw
23	B14X40401788	Screw
24	B16X40401788	Screw
25	TU4P	Extension 0.80 m
26	TU5P	Extension 1.45 m
27	DV9	Capping

8.4. Gauge wheels

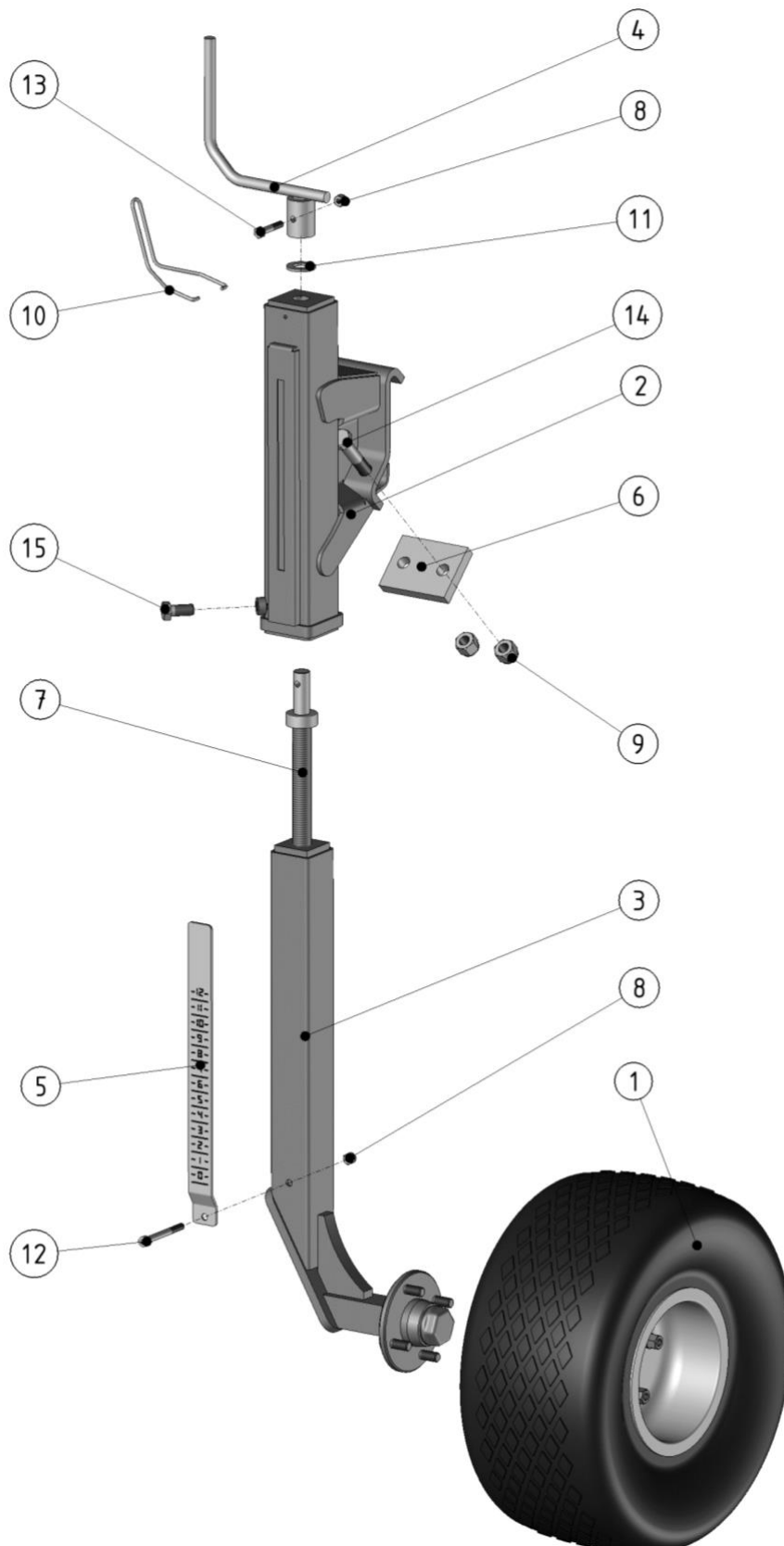

Nomenclature: Gauge wheels

Mark	Reference	Designation
1	DV10	Wheel 18.5 x 8.50 x 8
2	MS15P	Left gauge wheel fitting
	MS16P	Right gauge wheel fitting
3	MS17P	Wheel holder
4	US26Z	Handle
5	TL10Z	Graduation
6	US19Z	Rear flange
7	US27Z	Depth setting screw
8	BECHFR87040ZN	Nut
9	BECHFR167040ZN	Nut
10	PF3Z	Handle spring
11	BRD207089ZN	Washer
12	B8X80476288	Screw
13	B8X45401488	Screw
14	B16X80401488	Screw
15	B14X30401788	Screw

8.5. Parallelogram

8.5.1. Front box of parallelogram

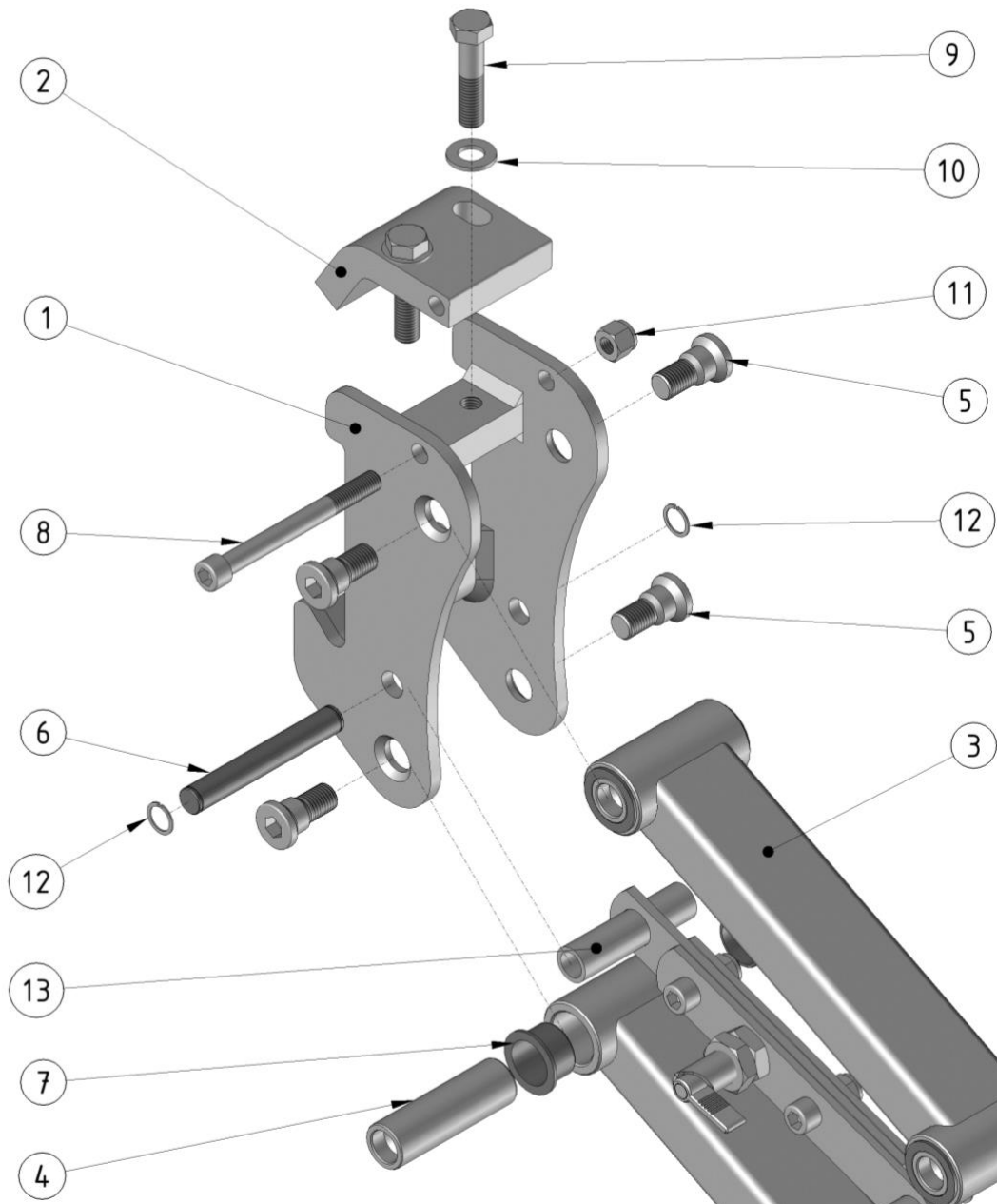

Nomenclature: Front box of parallelogram

Mark	Reference	Designation
1	MS1P	Front box
2	US9Z	Stopper
3	MS2P	Spreader
4	US7Z	Spreader bush
5	US8Z	Spreader screw
6	US10Z	Box axle
7	DV2	Bushing
8	B12X120476288	Screw
9	B14X60401488	Screw
10	BRD147089ZN	Washer
11	BECHFR127040ZN	Nut
12	BAEEXT16471	Snap ring
13	MS7Z	Male stopper slider

8.5.2. Rear box of parallelogram

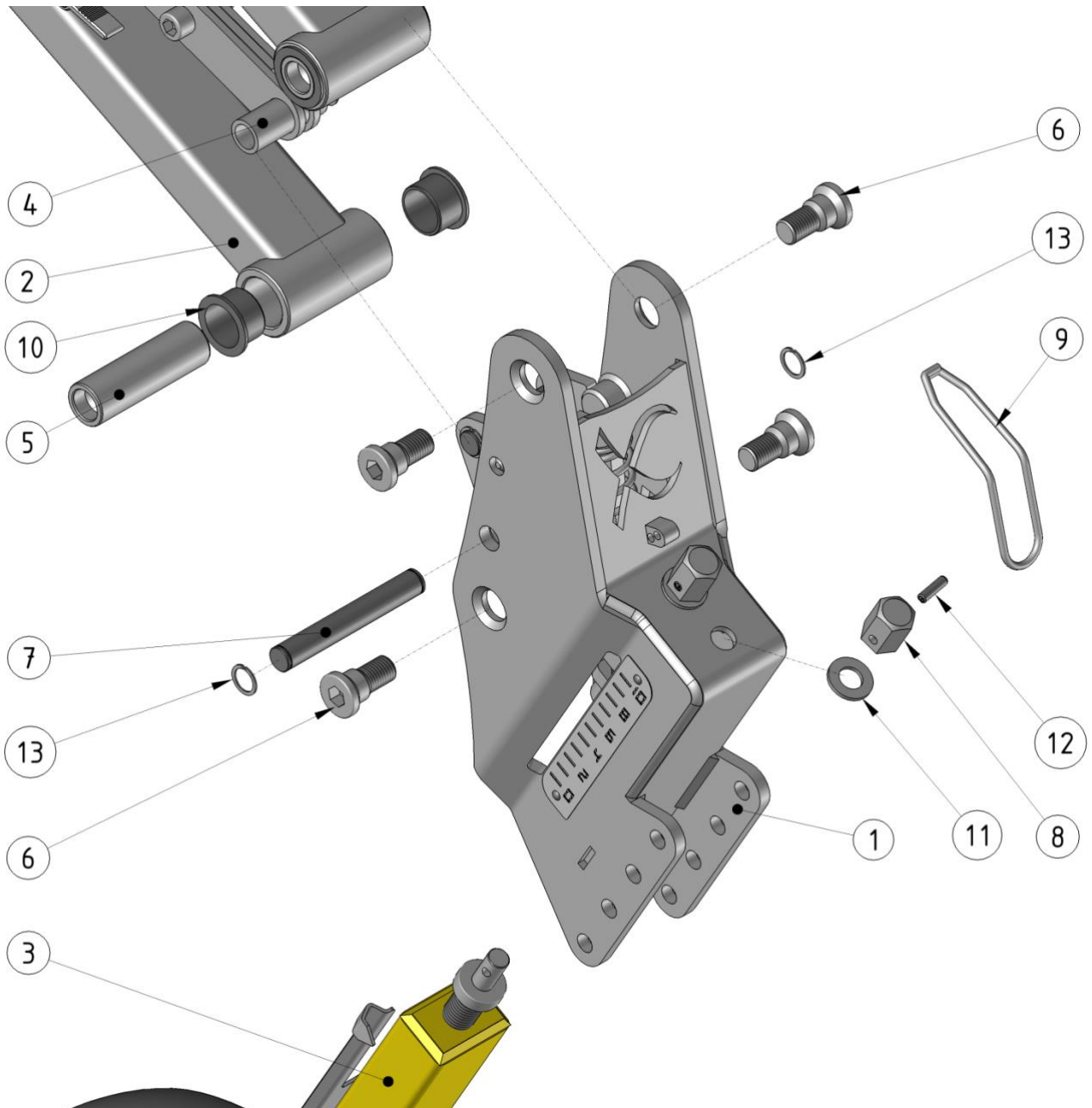

Nomenclature: Rear box of parallelogram

Mark	Reference	Designation
1	MS3P	Rear box
2	MS2P	Spreader
3	MS4P	Gauge wheel holder
4	MS6Z	Female stopper slider
5	US7Z	Spreader bush
6	US8Z	Spreader screw
7	US10Z	Box axle
8	US12Z	Setting nut
9	PF1Z	Lock spring
10	DV2	Bushing
11	BRD147089ZN	Washer
12	BGEEP6X228752	Spring pin
13	BAEEXT16471	Snap ring

8.5.3. Locking system and forced topsoiling

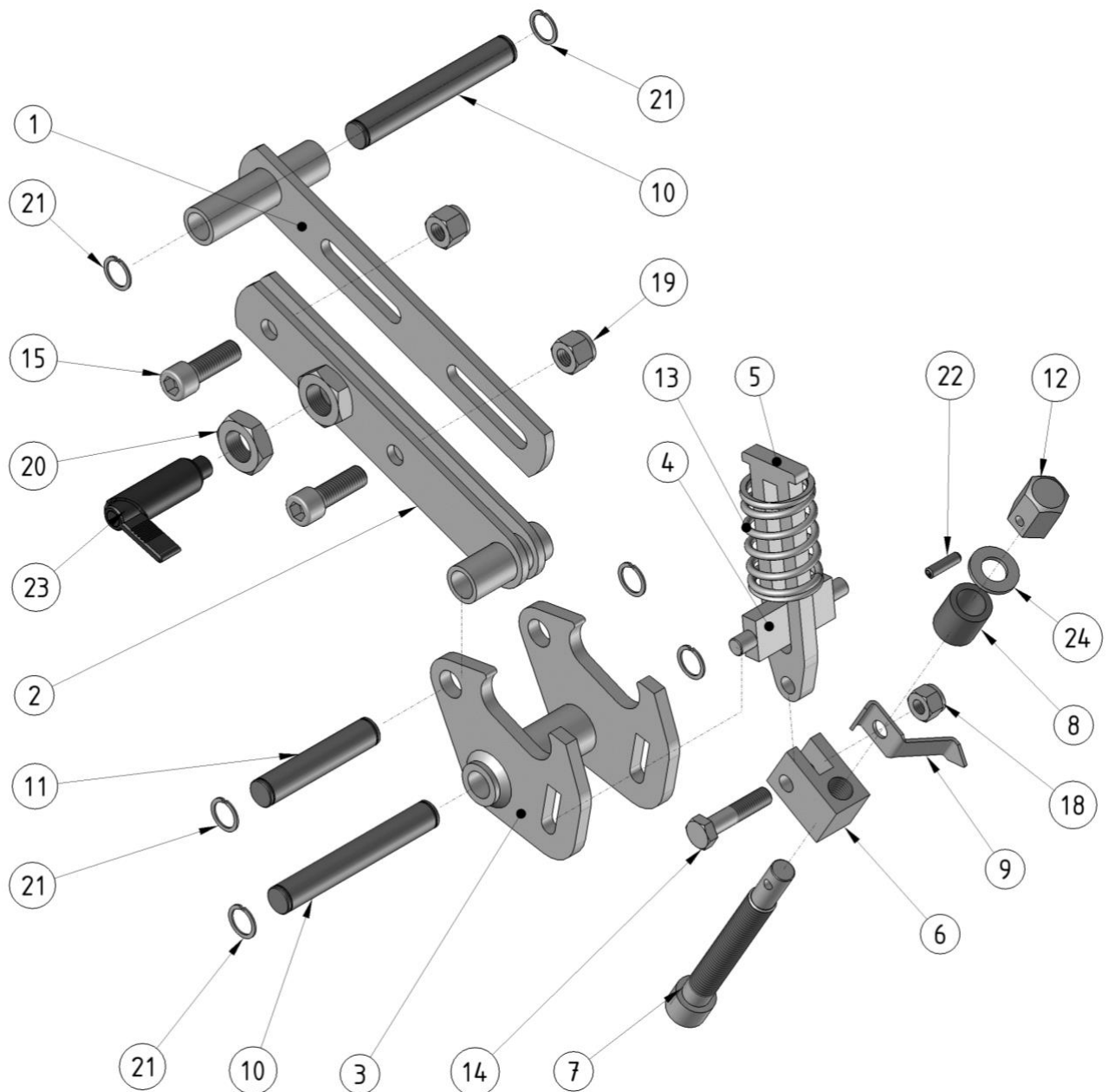

Nomenclature: Locking system and forced topsoiling

Mark	Reference	Designation
1	MS7Z	Male stopper slider
2	MS6Z	Female stopper slider
3	MS5Z	Pressure setting rocker
4	US4Z	Spring stop
5	US3Z	Pull
6	US5Z	Ball
7	US6Z	Depth setting screw
8	US45Z	Ball spacer
9	TL2Z	Depth setting pointer
10	US10Z	Box axle
11	US11Z	Tipper axler
12	US12Z	Setting nut
13	PF5Z	Loader spring
14	B10X45401488	Screw
15	B12X35476288	Screw
16	BTB8X1273801	Screw
17	BTB8X1673801	Screw
18	BECHFR107040ZN	Nut
19	BECHFR127040ZN	Nut
20	BECHBAS208675	Nut
21	BAEEXT16471	Snap ring
22	BGEEP6X228752	Spring pin
23	DV1	Pressure indicator
24	BRD147089ZN	Washer

8.5.4. Parallelogram's gauge wheel

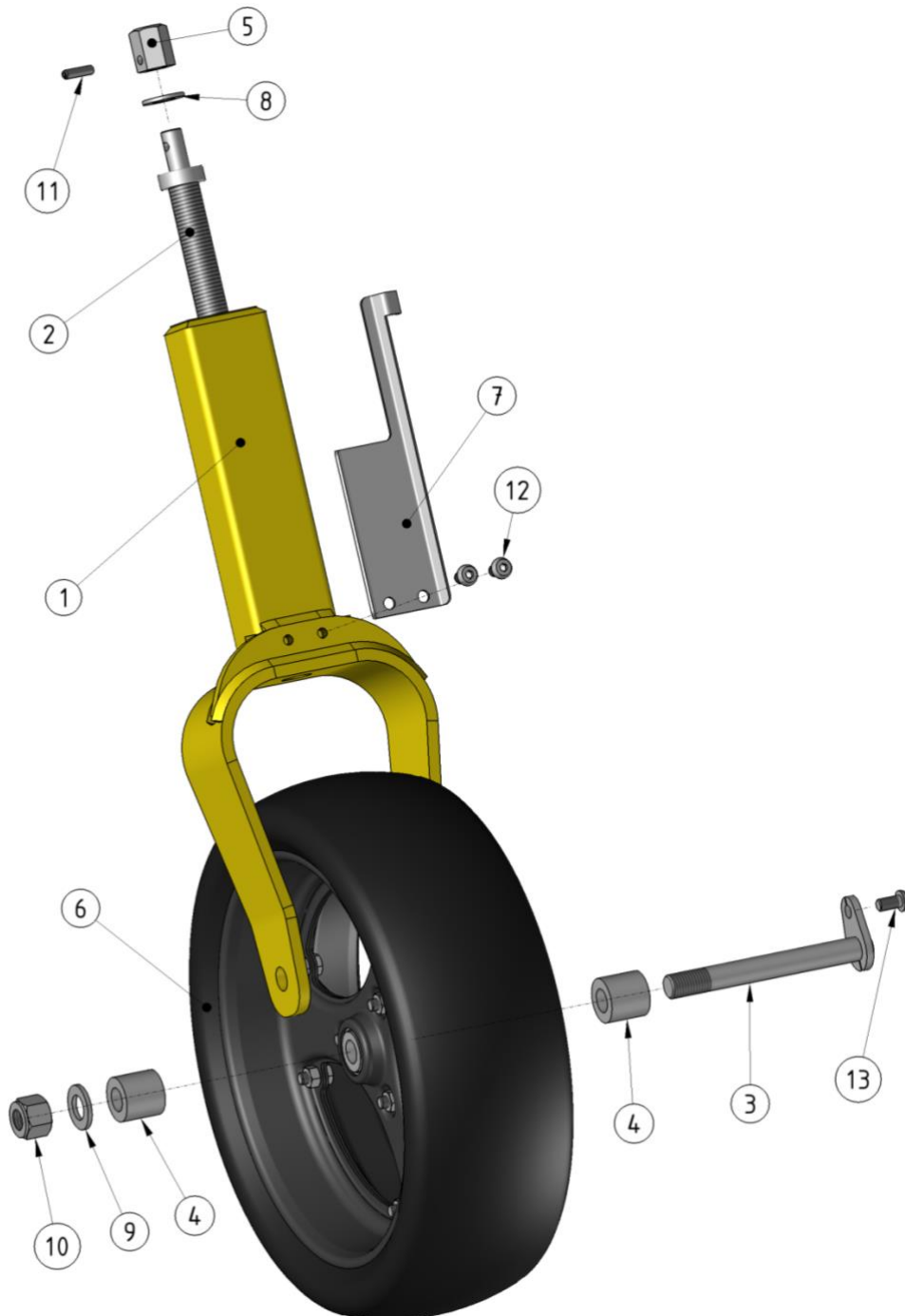

Nomenclature: Parallelogram's gauge wheel

Mark	Reference	Designation
1	MS4P	Gauge wheel holder
2	US2Z	Depth setting screw
3	MS8Z	Wheel axle
4	US1Z	Wheel spacer
5	US12Z	Setting nut
6	DV3	Ø355 x 120 wheel
7	TL1Z	Depth indicator
8	BRD147089ZN	Washer
9	BRD167089ZN	Washer
10	BECHFR167040ZN	Nut
11	BGEEP6X228752	Spring pin
12	BTB8X1273801	Screw
13	BTB8X1673801	Screw

8.6. Tine-holder elements

8.6.1. Tine-holders components

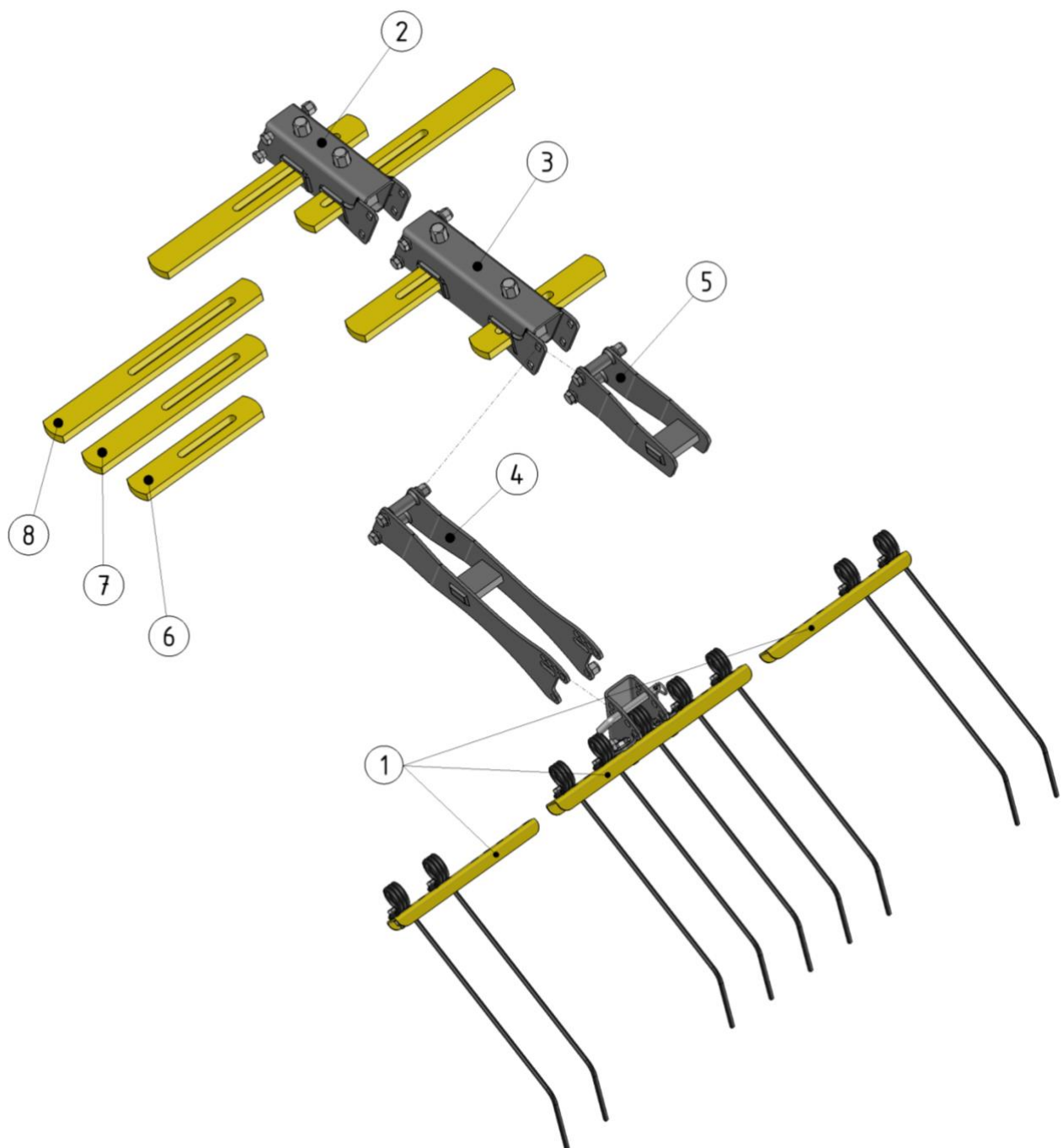

Nomenclature: Tine-holders components

Mark	Reference	Designation
1	SE60V	Comb harrow kit including: <ul style="list-style-type: none"> - 1 rear one-tine holder with comb harrow fitting - 1 comb tilting flange - 1 centre comb holder - 2 side comb holders - 9 410 mm-long \varnothing7 teeth
2	MS18P	Short holder element (without slider)
3	MS19P	Long holder element (without slider)
4	MS36P	Holder elements for 1 tooth and comb
5	MS20P	Holder elements for 1 tooth
6	US33P	250mm-long tooth holder slider
7	US32P	350mm-long tooth holder slider
8	US50P	420mm-long tooth holder slider

8.6.2. Tine-holders components

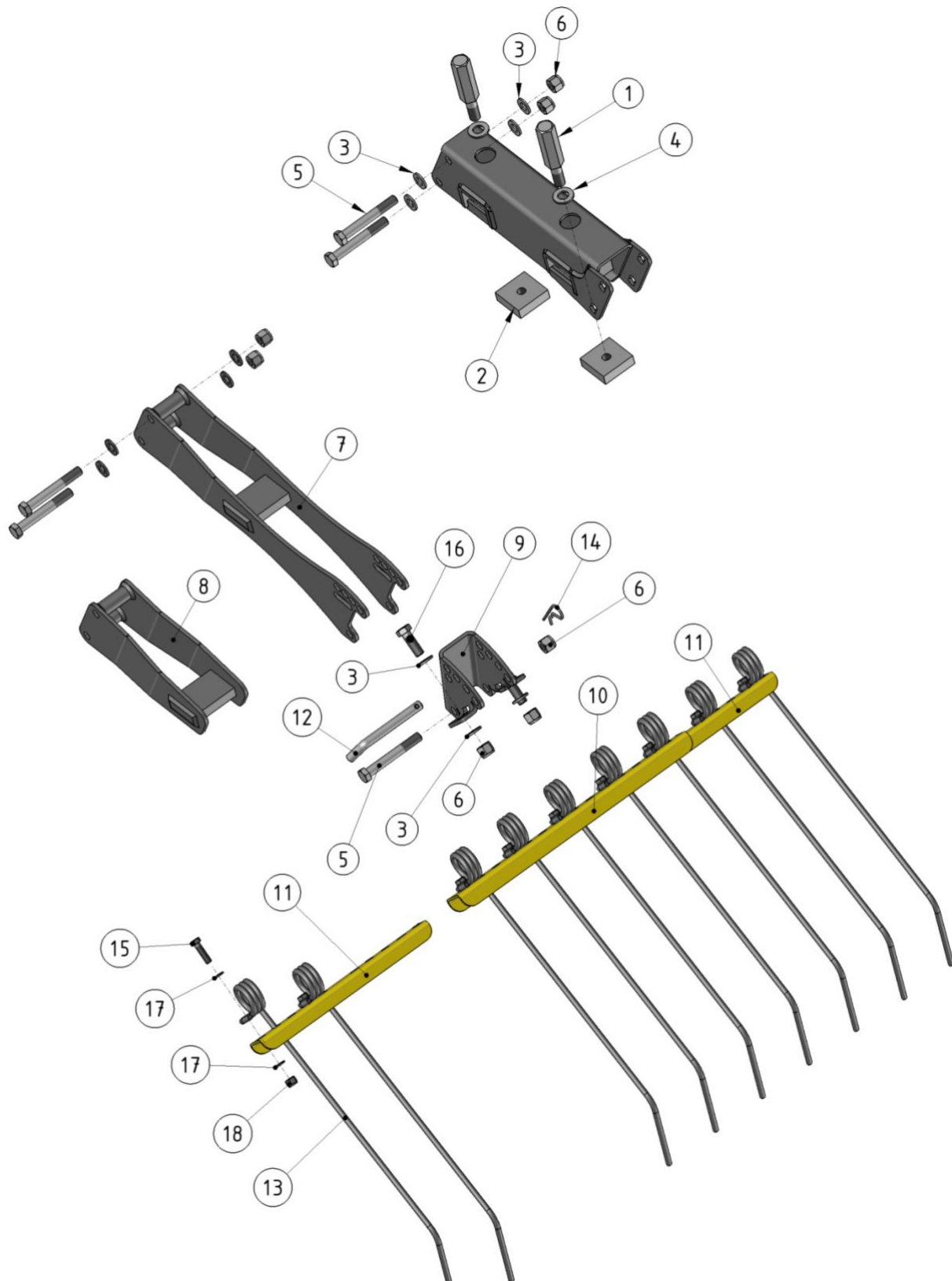

Nomenclature: Tine-holders components

Mark	Reference	Designation
1	US29Z	Tightening screw
2	US28Z	Flange plate
3	BRD127089ZN	Washer
4	BRD147089ZN	Washer
5	B12X90401488	Screw
6	BECHFR127040ZN	Nut
7	MS36P	Holder elements for 1 tooth and comb
8	MS20P	Holder elements for 1 tooth
9	US34P	Comb tilting flange
10	US35P	Centre comb-tooth holder
11	US36P	Side comb-tooth holder
12	US53Z	Setting axle
13	PU19B	Ø7 x 410 Tungsten carbide comb tooth
	PU20P	Ø7 x 410 comb tooth
	PU21P	Ø7 x 450 comb tooth
14	BGB3X67	Spring pin
15	B8X30401788	Screw
16	B12X35401788	Screw
17	BRD87089ZN	Washer
18	BECHFR87040ZN	Nut

8.6.3. Shear and teeth



Spring with shear
80mm Tungst. carb.
Ref: SE62V



Spring with shear
160mm Steel
Ref: SE8V



Spring with shear
200mm Steel
Ref: SE9V



Spring with shear
260mm Steel
Ref: SE10V



80mm-shear with
strut
Tungsten carbide
Ref: PU33P



160mm-shear
with strut
'Hardox' steel
Ref: PU3P
Tungsten carbide
Ref: PU34P



200mm-shear
with strut
'Hardox' steel
Ref: PU4P
Tungsten carbide
Ref: PU35P



260mm-shear
with strut
'Hardox' steel
Ref: PU5P
Tungsten carbide
Ref: PU36P



Spring with 120mm
Lelièvre blade
right
Ref: SE21V



Spring with 120mm
Lelièvre blade
left
Ref: SE22V



Fixed Lelièvre blade
strut
Ref: PU14P



Adjustable Lelièvre
blade strut
Ref: PU28P

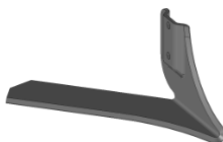

Left Lelièvre blade
120mm-long Ref:
PU7P
160mm-long Ref:
PU22P



Right Lelièvre blade
120mm-long Ref:
PU8P
160mm-long Ref:
PU23P

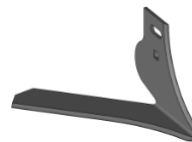

Left adjustable
Lelièvre blade
120mm-long Ref:
PU9P
160mm-long Ref:
PU24P



Right Lelièvre blade
adjustable
120mm-long Ref:
PU10P
160mm-long Ref:
PU25P



Vibrant tine 32 x 10
Ref: PU2P

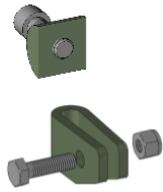

Flange kit
Ref: SE6V



Vibrant tine 32 x 12
Ref: PU12P



Tooth flange
Ref: DV11



150mm V-shear
Ref: PU11Z



200mm V-shear
Ref: PU37Z



250mm V-shear
Ref: PU38Z

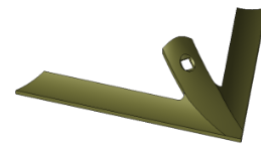

300mm V-shear
Ref: PU39Z



Left half-heart
Ref: PU26Z



Right half-heart
Ref: PU27Z



Left ridge coulter
Ref: PU40Z



Right ridge coulter
Ref: PU41Z

8.7. Protection disk

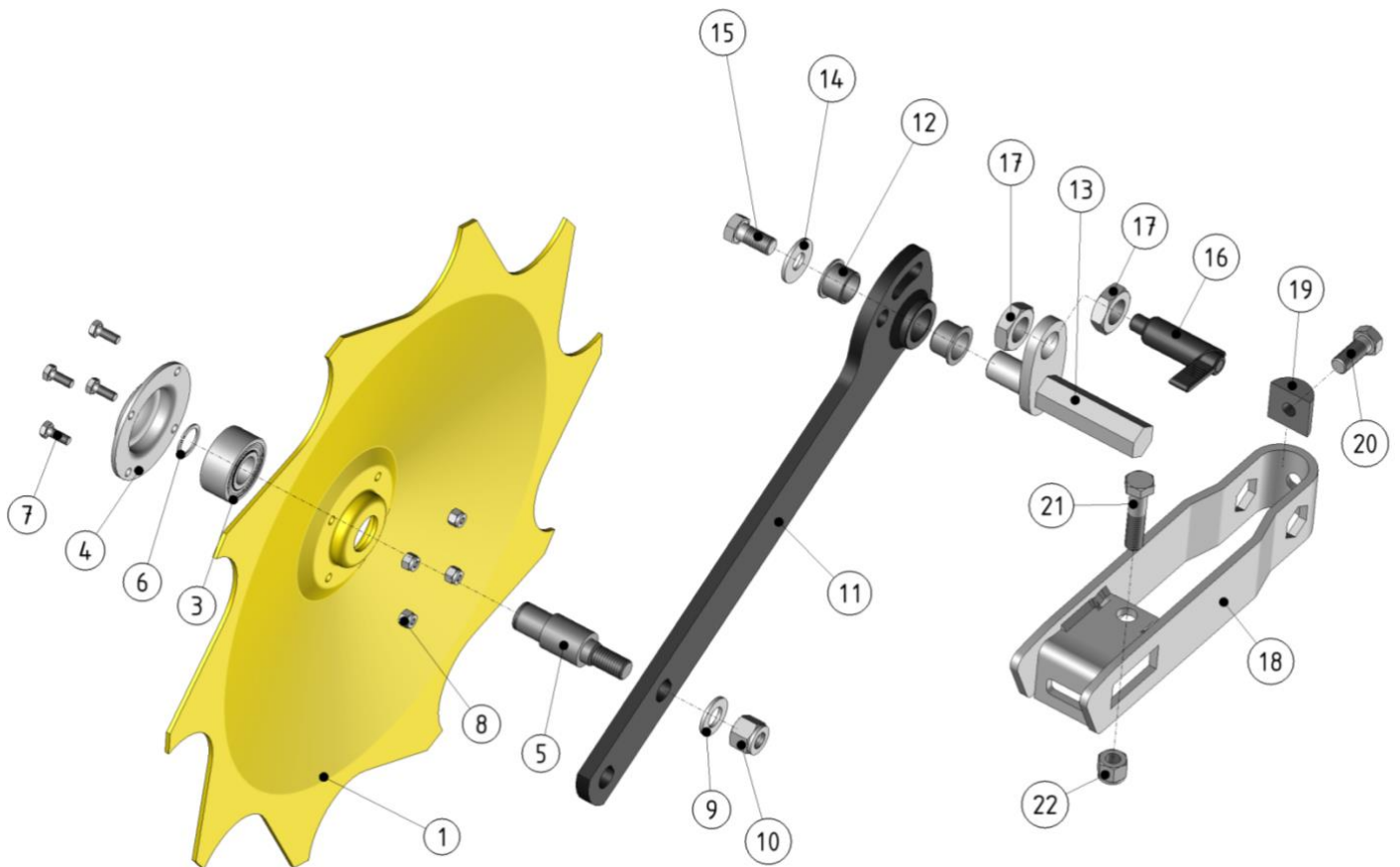

Nomenclature: Protection disk

Mark	Reference	Reference	Designation	
1	Right SE50V	MS47P	Left plant-protection discs	
		MS46P	Right plant-protection discs	
3		DV20	Bearing	
4		TL16Z	Bearing cage	
5		US43Z	Disc axle	
6		BAEEXT20471	Snap ring	
7		B6X16401788	Screw	
8		Left SE51V	BECHFR67040ZN	Nut
9			BRD147089ZN	Washer
10			BECHFR147040ZN	Nut
11	SE52V		MS45P	Disc-holder arm
12		DV53	Bushing	
13	SE53V	US56Z	Slide	
14		BRDL1225513ZN	Washer	
15		B12X25401788	Screw	
16		DV1	Pressure indicator	
17		BECHBAS208675	Lower nut	
18	SE54V	MS64P	Disk support	
19		US41Z	Spacer	
20		B12X35401788	Screw	
21		B12X50401488	Screw	
22		BECHFR127040ZN	Nut	

8.8. Flexible weeder fingers

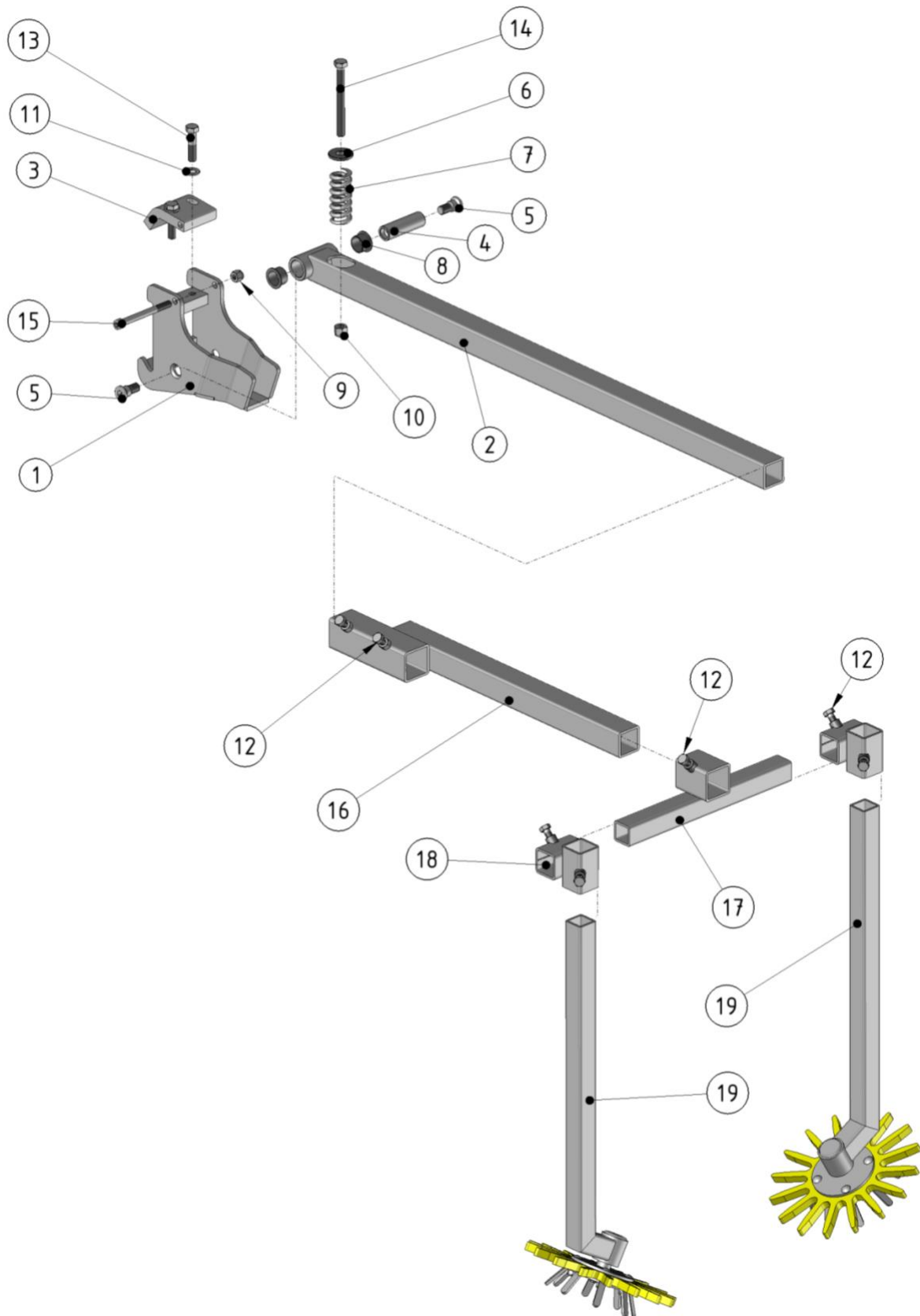

Nomenclature: Flexible weeder fingers

Mark	Reference	Designation
1	MS68P	Flexible fingers front support box
2	MS69P	Flexible fingers support arm
3	US9Z	Stopper
4	US7Z	Spreader bush
5	US8Z	Spreader screw
6	US57Z	Spring washer
7	PF6Z	Loader spring
8	DV2	Skirt bushing
9	BECHFR127040ZN	Nut
10	BECHFR147040ZN	Nut
11	BRD147089ZN	Washer
12	B12X35401788	Screw
13	B14X60401488	Screw
14	B14X140401788	Screw
15	B12X120476288	Screw
16	MS71P	Extensions
17	DV50	Support
18	DV49	Fitting cross
19	DV47	Flexible fingers weeder element

8.9. Road lighting equipment

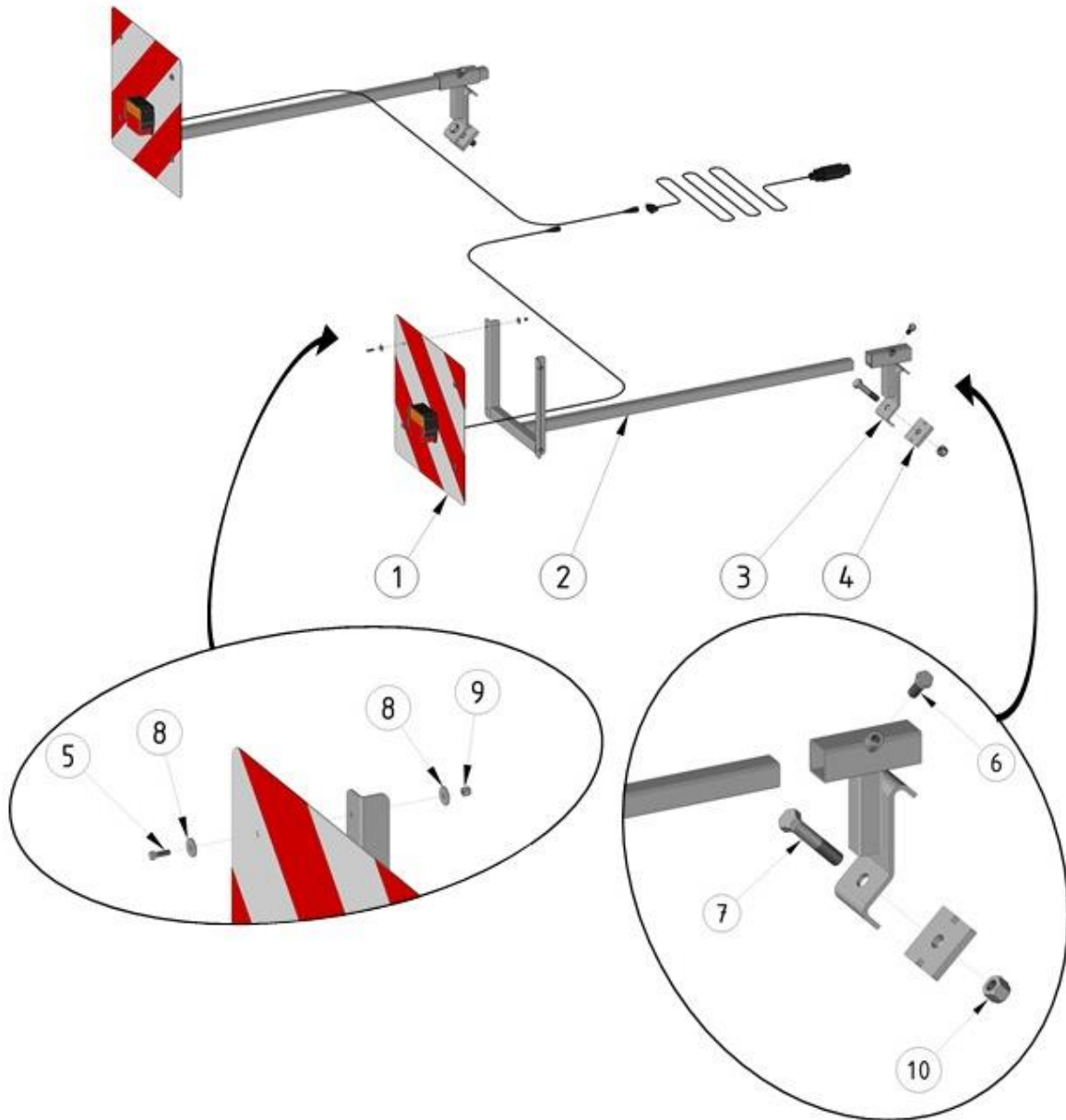

Nomenclature: Road lighting equipment

Mark	Reference	Designation
1	DV45	Plates kit with lamp and wires
2	MS67P	Long plate holder
3	MS66P	H-beam plate holder bracket
4	US52Z	Holder flange
5	B5X16401788	Screw
6	B12X35401788	Screw
7	B16X80401488	Screw
8	BRD057089ZN	Washer
9	BECHFR57040ZN	Nut
10	BECHFR167040ZN	Nut

BC TECHNIQUE AGRO-ORGANIQUE offers some optional equipment and other adaptations whose characteristics may be provided on request.

9. Notes



B.C TECHNIQUE AGRO-ORGANIQUE S.A.S.

Bois Choppard

F – 89270 VERMENTON

Phone : +33 (0)3 86 34 31 64

@: commercial@bc-technique.com